

Data sheet

POWERLINE MP52.4 MP52.5

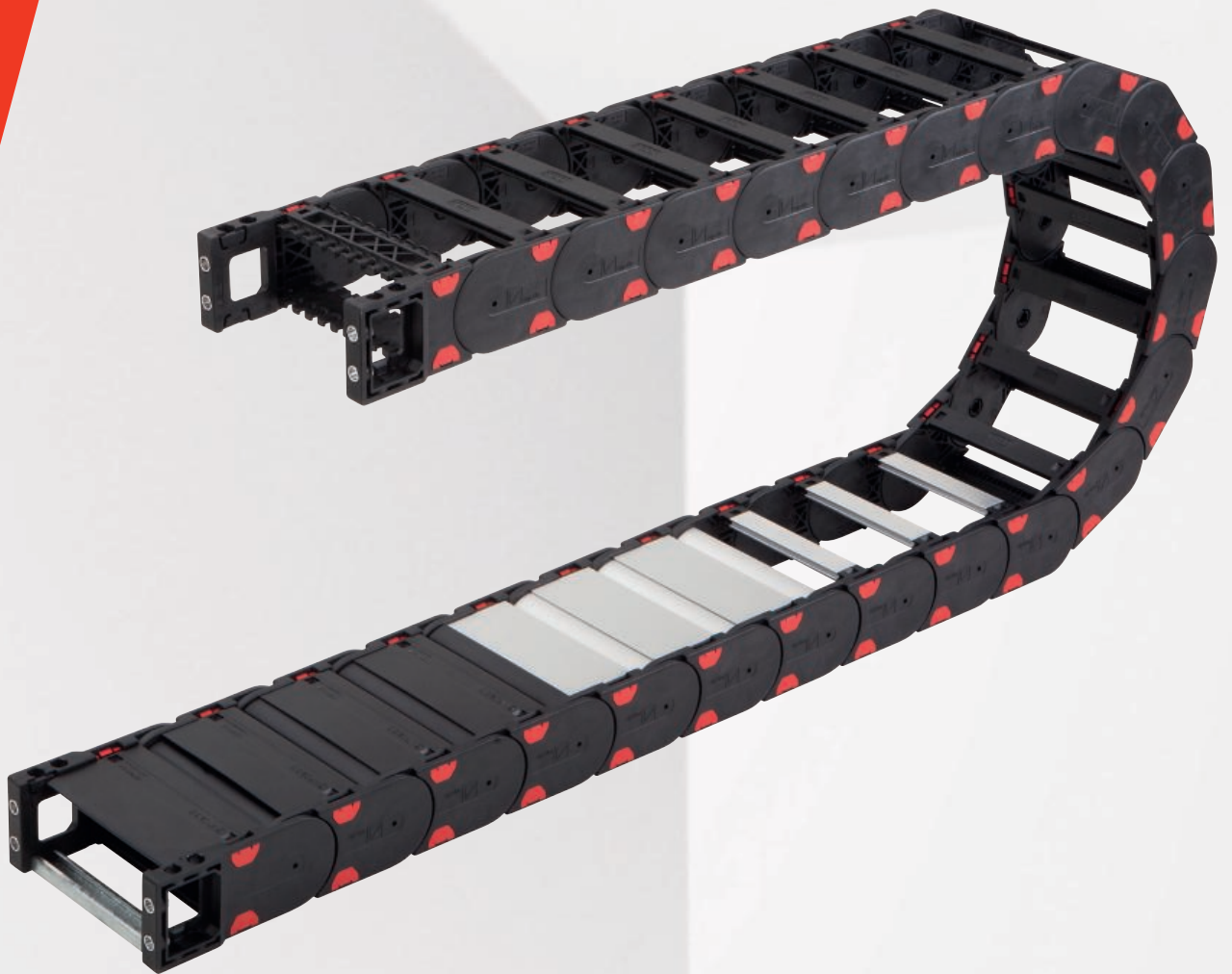

murrplastik[®]
Simply Smart Systems



MP 52.4 OPEN / MP 52.4 CLOSED

52.4
OPEN

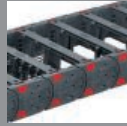

52.5
CLOSED

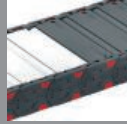

POWERLINE

- LOW-COST VARIANT
- SOFT-STOP SYSTEM
- FLEXIBLE CHAIN BRACKET
- BROAD INTERIOR LAYOUT
- PLASTIC AND ALUMINUM VERSION

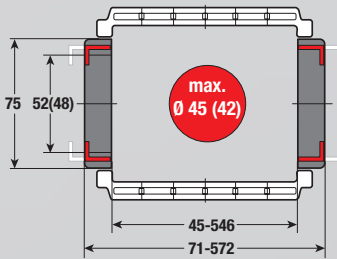

TECHNICAL DATA

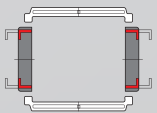

Loading side
Inside and outside bend

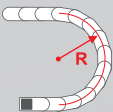

Available radii
125.0 - 300.0 mm

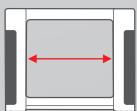

Available interior widths
With plastic crossbar
45.0 - 546.0 mm
With aluminum crossbar / With aluminum cover
67.0 - 600.0 mm / 43.0 - 600.0 mm

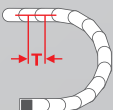

Grid
T = 91.0 mm



Noise attenuator
Reduction of the noise emission by up to 10 dB(A)
by using damping elements in the chain links.

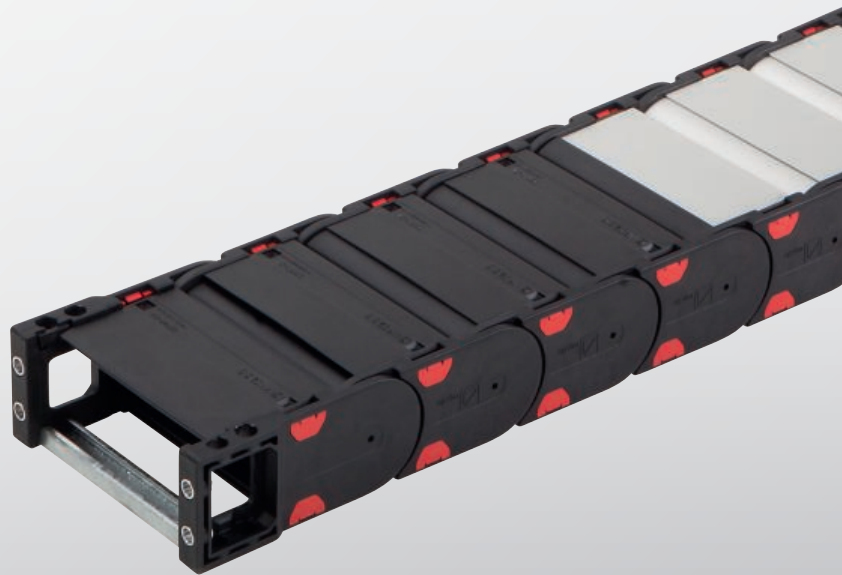
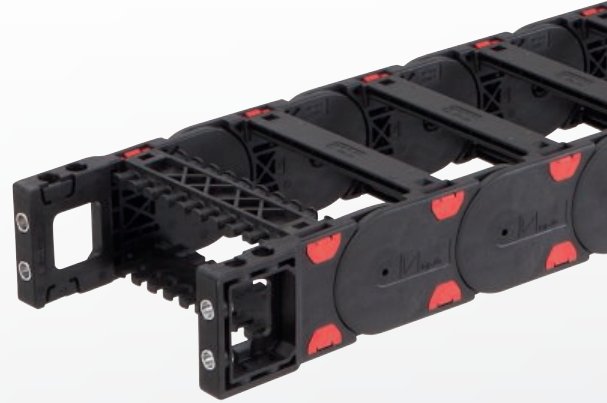



TECHNICAL SPECIFICATIONS

Travel distance gliding L_g max.	50.0 m
Travel distance self-supporting L_f max.	see diagram on page 5
Travel distance vertical, hanging L_{vh} max.	50.0 m
Travel distance vertical, standing L_{vs} max.	4.0 m
Rotated 90°, self-supporting L_{90f} max.	1.0 m
Speed, gliding V_g max.	5.0 m/s
Speed, self-supporting V_f max.	20.0 m/s
Acceleration, gliding a_g max.	25.0 m/s ²
Acceleration, self-supporting a_f max.	30.0 m/s ²

Contact our engineering department to meet any higher requirements: efk@murrplastik.de

MATERIAL PROPERTIES

Standard material	Polyamide (PA) black
Service temperature	-30.0 - 120.0 °C (-76 to 176 °F)
Gliding friction factor	0.3
Static friction factor	0.45
Fire classification	UL 94 HB

Other material properties on request.

ACCESSORIES

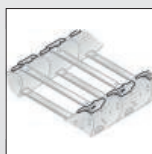

Gliding shoes

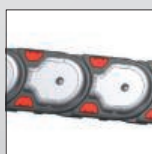

Gliding plate



Bracket bar

SHELVING SYSTEM

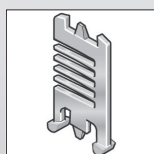

TR separator

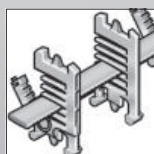

RS shelving system

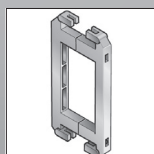

Crossbar connector RSV

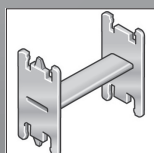

H-shaped shelf unit (RE)

CHAIN BRACKET

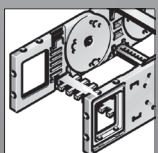

Flexible chain bracket

GUIDE CHANNELS

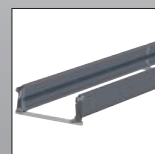

VAW
Steel galvanized/stainless steel



VAW aluminum

STRAIN RELIEF

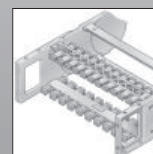

Crossbar RS-ZL

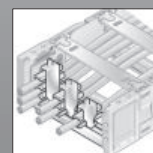

STF Steel Fix

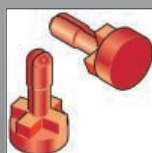

Lock button

MP 52.4 OPEN / MP 52.4 CLOSED

ORDER KEY

Dimensions in mm [US inch]

Type code	Variant	Inside width	Outside width	Inside width	Outside width	Radius	Crossbar variant	Material	Chain length
0524 30	MP 52.4 open Crossbar in outside bend Crossbar in inside bend Opens on inside and outside bend	045 ¹⁾ [1.77]	071 [2.80]	233 [9.17]	259 [10.20]	125 ¹⁾ [4.92]	0 Plastic, full-ridged with bias	2 Polyamide without attenuator (PA/black)	
		057 ¹⁾ [2.24]	083 [3.27]	246 ²⁾ [9.69]	272 [10.71]				
0525 44 ³⁾	MP 52.5 closed Cover in outside bend Cover in inside radius Opens on inside and outside bend	062 ¹⁾ [2.44]	088 [3.46]	252 [9.92]	278 [10.94]	135 ¹⁾ [5.31]	1 Plastic, full-ridged without bias	3 Polyamide with attenuator (PA/black)	
		071 [2.80]	097 [3.82]	258 [10.16]	284 [11.18]				
		084 [3.31]	110 [4.33]	296 ²⁾ [11.65]	322 [12.68]	150 [5.91]	2 Plastic, half-ridged with bias	7 ESD (PA/light gray) (upon request)	
		093 [3.66]	119 [4.69]	346 ²⁾ [13.62]	372 [14.65]				
		096 ²⁾ [3.78]	122 [4.80]	350 [13.78]	376 [14.80]	175 [6.89]	3 Plastic, half-ridged without bias	9 Special version (on request)	
		104 [4.09]	130 [5.12]	358 [14.09]	384 [15.12]				
		107 [4.21]	133 [5.24]	371 [14.61]	397 [15.63]	200 [7.87]	4 Aluminum full-ridged with bias		
		121 ²⁾ [4.76]	147 [5.79]	396 [15.59]	422 [16.61]				
		133 [5.24]	159 [11.42]	421 [16.57]	447 [17.60]	250 [9.84]	5 Aluminum full-ridged without bias		
		144 [5.67]	170 [6.69]	446 [17.56]	472 [18.58]				
		146 ²⁾ [5.75]	172 [6.77]	496 [19.53]	522 [20.55]	300 [11.81]	6 Aluminum half-ridged with bias		
		158 [6.22]	184 [7.24]	546 [21.50]	572 [22.52]				
		164 [6.46]	190 [7.48]				7 Aluminum half-ridged without bias		
		171 [6.73]	197 [7.76]						
		182 ²⁾ [7.17]	208 [8.19]				9 Special version (on request)		
		196 ²⁾ [7.72]	222 [8.74]						
		208 [8.19]	234 [9.21]						
		220 ²⁾ [8.66]	246 [9.69]						

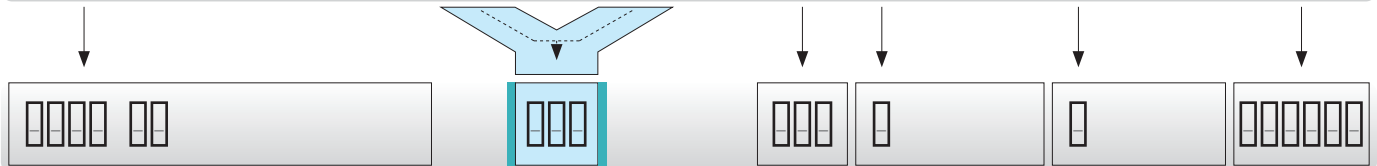

ORDERING EXAMPLE: 0524 30 220 150 0 3 2548

Crossbar in outside bend, crossbar in inside bend, can be opened from inside and outside bend
 Inside width 220 mm, radius 3.93 in (150 mm)
 Plastic, full-ridged with bias, material polyamide with damper (PA/black)
 Chain length 2548 mm (28 links)

¹⁾ For variant MP 52.4 only
²⁾ MP 52.5 also available with plastic cover
³⁾ reduced inner height, reduced max. cable diameter, see chain window drawing Page 2

NOTE ON CONFIGURATION

Aluminum crossbars:

Aluminum crossbars can be supplied in 1 mm width sizes for inner widths from 67.0 mm – 600.0 mm.

Aluminum covers:

Aluminum crossbars can be supplied in 1 mm width sizes for inner widths from 43.0 mm – 600.0 mm.

Crossbar connector and crossbar strain relief plate:

Once inside widths exceed 9.69 in (246 mm), we recommend the deployment of crossbar connectors (RSV).

Crossbar connectors cannot be used in conjunction with covers made from plastic or aluminum.

If crossbar strain relief plates (RS-ZL) are to be deployed in the chain brackets, take standard inside widths into account.

For detailed information, please consult the corresponding product documentation.

SELF-SUPPORTING LENGTH

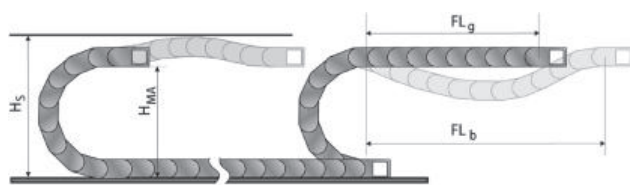

The self-supporting length is the distance between the chain bracket on the moving end and the start of the chain arch.

The installation variant FL_g offers the lowest load and wear for the energy chain.

The maximum travel parameters (speed and acceleration) can be applied for this variant.

H_s = Installation height plus safety

H_{MA} = Height of moving end bracket

FL_g = Self-supporting length, upper run straight

FL_b = Self-supporting length, upper run bent

LOAD DIAGRAM FOR SELF-SUPPORTING APPLICATIONS

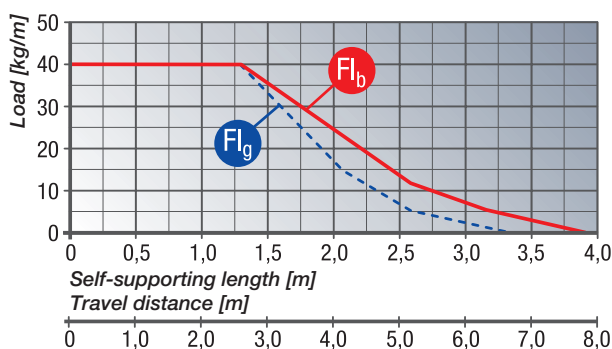

FL_g Self-supporting length, upper run straight

In the FL_g range, the chain upper run still has a bias, is straight or has a maximum sag of 70.0 mm.

FL_b Self-supporting length, upper run bent

In the FL_b range, the chain upper run has a sag of more than 70.0 mm, but this is still less than the maximum sag.

Where the sag is greater than that permitted in the FL_b range, the application is critical and should be avoided. The self-supporting length can be optimized by using a support for the upper run or a more stable energy chain.

Closed cable drag chains (with covers) have a higher unit weight than open chains (with crossbars). This higher weight must be taken into account when calculating the self-supporting length. To the weight of the cables (payload, in kg/m), 1. kg/m must be added for the higher weight of the closed covers.

MP 52.4 OPEN / MP 52.4 CLOSED

DETERMINING THE CHAIN LENGTH

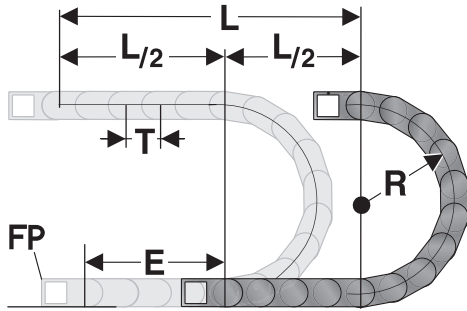

The fixed point of the energy chain should be connected in the middle of the travel distance.
This arrangement gives the shortest connection between the fixed point (FP) and the moving bracket and thus the most efficient chain length.

Chain length calculation = $L/2 + \pi * R + E$
 $\approx 1 \text{ m chain} = 11 \text{ links, } 91.0 \text{ mm each}$

- E = Distance between entry point and middle of travel distance
- L = Travel distance
- R = Radius
- T = Grid 91.0 mm

INSTALLATION DIMENSIONS

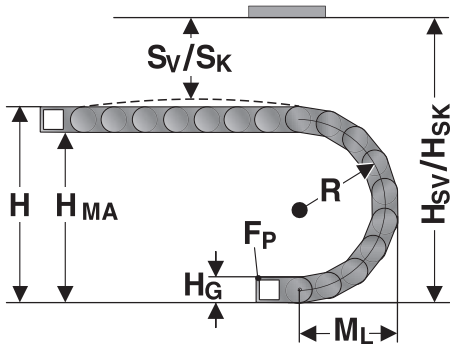

The moving end chain bracket is to be screw fixed at height H_{MA} for the respective radius.
Concerning the installation dimensions take into consideration, whether the chain links are equipped with damping elements or not.
For chain links without damping elements, the value "Installation height with bias H_{sv} without damper" or "Installation height without bias H_{sk} without damper" must be observed.
If the chain links are equipped with damping elements, the value "Installation height with bias H_{sv} with damper" or "Installation height without bias H_{sk} with damper" must be observed.

Radius R	125	135	150	175	200	250	300
Outside height of chain link (H_g)	75	75	75	75	75	75	75
Height of bend (H)	325	345	375	425	475	575	675
Height of moving end bracket (H_{MA})	250	270	300	350	400	500	600
Safety margin with bias (S_v)	20	20	20	20	20	20	20
Installation height with bias (H_{sv}) without damper	405	425	455	505	555	655	755
Installation height with bias (H_{sv}) with damper	435	455	485	535	585	685	785
Safety margin without bias (S_k)	20	20	20	20	20	20	20
Installation height without bias (H_{sk}) without damper	345	365	395	445	495	595	695
Installation height without bias (H_{sk}) with damper	375	395	425	475	525	625	725
Arc projection (M_L)	254	264	279	304	329	379	429

DAMPING ELEMENTS FOR THE SIDE LINKS

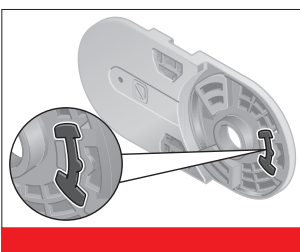

The dampening elements in the stops make for a significantly quieter unrolling of the chain links. The dampers can be chosen optionally.
A reduction of the noise emission by up to 10 dB(A) comparing to the variants without the use of damping elements is possible.

POWERLINE PLASTIC CROSSBAR

Crossbar

The crossbars connect the two side runs of the energy chains. The crossbar length is synonymous with the inside width of the energy chain.

Type	Order No.	Description	Inside width mm
RS 045-5	052004500000	Crossbar	45.0
RS 057-5	052005700000	Crossbar	57.0
RS 062-5	052006200000	Crossbar	62.0
RS 071-5	052007100000	Crossbar	71.0
RS 084-5	052008400000	Crossbar	84.0
RS 093-5	052009300000	Crossbar	93.0
RS 096-5	052009600000	Crossbar	96.0
RS 104-5	052010400000	Crossbar	104.0
RS 107-5	052010700000	Crossbar	107.0
RS 121-5	052012100000	Crossbar	121.0
RS 133-5	052013300000	Crossbar	133.0
RS 144-5	052014400000	Crossbar	144.0
RS 146-5	052014600000	Crossbar	146.0
RS 158-5	052015800000	Crossbar	158.0
RS 164-5	052016400000	Crossbar	164.0
RS 171-5	052017100000	Crossbar	171.0
RS 182-5	052018200000	Crossbar	182.0
RS 196-5	052019600000	Crossbar	196.0
RS 208-5	052020800000	Crossbar	208.0
RS 220-5	052022000000	Crossbar	220.0
RS 233-5	052023300000	Crossbar	233.0
RS 246-5	052024600000	Crossbar	246.0
RS 252-5	052025200010	Crossbar	252.0
RS 258-5	052025800000	Crossbar	258.0
RS 296-5	052029600000	Crossbar	296.0
RS 346-5	052034600000	Crossbar	346.0
RS 350-5	052035000000	Crossbar	350.0
RS 358-5	052035800000	Crossbar	358.0
RS 371-5	052037100000	Crossbar	371.0
RS 396-5	052039600000	Crossbar	396.0
RS 421-5	052042100000	Crossbar	421.0
RS 446-5	052044600000	Crossbar	446.0
RS 496-5	052049600000	Crossbar	496.0
RS 546-5	052054600000	Crossbar	546.0

MP 52.3 / MP 52.5 PLASTIC COVER

Cover

The covers connect the two side runs of the energy chain. The cover length is synonymous with the inside width of the energy chain.

Type	Order No.	Description	Installation site	Inside width mm
A-523062, outside	052306210000	Cover	Outside bend	62.0
I-523062, inside	052306220000	Cover	Inside bend	62.0
A-523096, outside	052309610000	Cover	Outside bend	96.0
I-523096, inside	052309620000	Cover	Inside bend	96.0
A-523121, outside	052312110000	Cover	Outside bend	121.0
I-523121, inside	052312120000	Cover	Inside bend	121.0
A-523146, outside	052314610000	Cover	Outside bend	146.0
I-523146, inside	052314620000	Cover	Inside bend	146.0
A-523182, outside	052318210000	Cover	Outside bend	182.0
I-523182, inside	052318220000	Cover	Inside bend	182.0
A-523196, outside	052319610000	Cover	Outside bend	196.0
I-523196, inside	052319620000	Cover	Inside bend	196.0
A-523220, outside	052322010000	Cover	Outside bend	220.0
I-523220, inside	052322020000	Cover	Inside bend	220.0
A-523246, outside	052324610000	Cover	Outside bend	246.0
I-523246, inside	052324620000	Cover	Inside bend	246.0
A-523296, outside	052329610000	Cover	Outside bend	296.0
I-523296, inside	052329620000	Cover	Inside bend	296.0
A-523346, outside	052334610000	Cover	Outside bend	346.0
I-523346, inside	052334620000	Cover	Inside bend	346.0

KA 52.4 FLEXIBLE CHAIN BRACKET

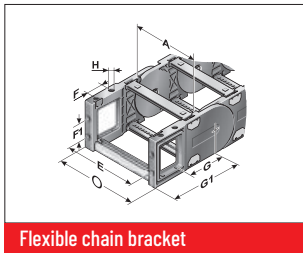

Flexible chain bracket

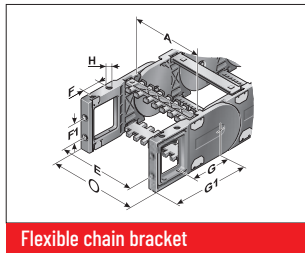

Flexible chain bracket

This chain bracket offers universal connection options (top, bottom and front) and is attached to the ends of the chain like a side link. This allows the chain to move right up to the bracket. Each chain requires one male and one female bracket. M8 screws and insert panels are used to secure the brackets in place. This chain bracket offers universal connection options (top, bottom and front) and is attached to the ends of the chain like a side link.

Type	Order No.	Material	Version	Inside width							Outside width KA	
				A mm	E mm	F mm	F1 mm	G mm	G1 mm	H mm	HØ mm	O mm
KA 52.4-FB female	0524000050	Plastic	with socket	45.0 - 546.0	A+16.0	20.0	30.0	85.0	125.0	9.0		A+34.0
KA 52.4-FB Female end, pendular	0524000052	Plastic	with socket	45.0 - 546.0	A+16.0	20.0	30.0	85.0	125.0	9.0		A+34.0
KA 52.4-FB male	0524000051	Plastic	with socket	45.0 - 546.0	A+16.0	20.0	30.0	85.0	125.0	9.0		A+34.0
KA 52.4-FG female end	0524000053	Plastic	with thread	45.0 - 546.0	A+16.0	20.0	30.0	85.0	125.0	M8		A+34.0
KA 52.4-FG Female end, pendular	0524000055	Plastic	with thread	45.0 - 546.0	A+16.0	20.0	30.0	85.0	125.0	M8		A+34.0
KA 52.4-FG male	0524000054	Plastic	with thread	45.0 - 546.0	A+16.0	20.0	30.0	85.0	125.0	M8		A+34.0

ASSEMBLY INSTRUCTION FB/FG FLEXIBLE CHAIN BRACKET

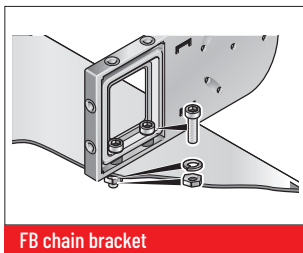

FB chain bracket

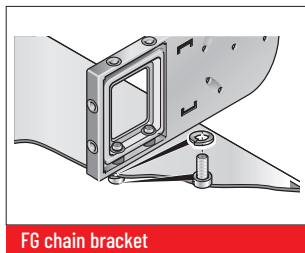

FG chain bracket

Brass bushes guarantee long-lasting fastening without cold flow in the plastic.

Type KA-FB:

Integrated through-hole fastened down using screw and nut.

Type KA-FG:

Built-in threads allow for quick and easy on-site mounting, since a screw, including a retaining washer where necessary, is sufficient.

GS 52.4 GLIDING SHOE

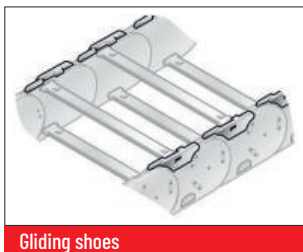

Gliding shoes

In the case of energy chains, gliding shoes are used in a horizontally sliding installation mode (the upper run of the chain glides on the lower run). The gliding shoes are set onto the side links on the interior bend instead of the usual crossbar interlocks; (no tools required). This forces the chain to slide on the gliding shoes instead on the side links of the chain.

Depending on the application, the service life of the energy chain may be extended five-fold, by using gliding shoes.

Information about the minimum bending radius of the cable drag chain at the gliding shoe insert is listed in the following table.

Type	Order No.	Installation site	Min. radius mm	Gliding shoe height mm
GS 52.4.1 right	052490400302	For right side link	150.0	4.0
GS 52.4.2 left	052490400300	For left side link	150.0	4.0

GLP 5 (52.4) GLIDING PLATE

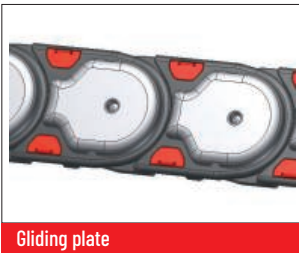

Gliding plate

The gliding plates are mounted in a horizontal position, with the chain laying on its side, to minimize friction wear to the sides. They are mounted to the side links using a special screw. The wear limit is 0.10 in (2.5 mm). We recommend replacing the cable drag chain when this limit has been reached. Depending on the application, the service life of the cable drag chain may be extended two-fold, by using gliding plates. The cable drag chain can also be opened in the lateral position.

Type	Order No.	Installation site	for radius mm	Gliding plate height mm
SG 52.4 RK125.1 right with GLP5, mounted	052400012566	Right chain link including gliding plate	125.0	7.0
SG 52.4 RK125.2 left with GLP5, mounted	052400012564	Left chain link including gliding plate	125.0	7.0
SG 52.4 RK135.1 right with GLP5, mounted	052400013566	Right chain link including gliding plate	135.0	7.0
SG 52.4 RK135.2 left with GLP5, mounted	052400013564	Left chain link including gliding plate	135.0	7.0
SG 52.4 RK150.1 right with GLP5, mounted	052400015066	Right chain link including gliding plate	150.0	7.0
SG 52.4 RK150.2 left with GLP5, mounted	052400015064	Left chain link including gliding plate	150.0	7.0
SG 52.4 RK175.1 right with GLP5, mounted	052400017566	Right chain link including gliding plate	175.0	7.0
SG 52.4 RK175.2 left with GLP5, mounted	052400017564	Left chain link including gliding plate	175.0	7.0
SG 52.4 RK200.1 right with GLP5, mounted	052400020066	Right chain link including gliding plate	200.0	7.0
SG 52.4 RK200.2 left with GLP5, mounted	052400020064	Left chain link including gliding plate	200.0	7.0
SG 52.4 RK250.1 right with GLP5, mounted	052400025066	Right chain link including gliding plate	250.0	7.0
SG 52.4 RK250.2 left with GLP5, mounted	052400025064	Left chain link including gliding plate	250.0	7.0
SG 52.4 RK300.1 right with GLP5, mounted	052400030066	Right chain link including gliding plate	300.0	7.0
SG 52.4 RK300.2 left with GLP5, mounted	052400030064	Left chain link including gliding plate	300.0	7.0
SG 52.4-D RK125.1 right with GLP5, mounted	052400012596	Right chain link including gliding plate	125.0	7.0
SG 52.4-D RK125.2 left with GLP5, mounted	052400012594	Left chain link including gliding plate	125.0	7.0
SG 52.4-D RK135.1 right with GLP5, mounted	052400013596	Right chain link including gliding plate	135.0	7.0
SG 52.4-D RK135.2 left with GLP5, mounted	052400013594	Left chain link including gliding plate	135.0	7.0
SG 52.4-D RK150.1 right with GLP5, mounted	052400015096	Right chain link including gliding plate	150.0	7.0
SG 52.4-D RK150.2 left with GLP5, mounted	052400015094	Left chain link including gliding plate	150.0	7.0
SG 52.4-D RK175.1 right with GLP5, mounted	052400017596	Right chain link including gliding plate	175.0	7.0
SG 52.4-D RK175.2 left with GLP5, mounted	052400017594	Left chain link including gliding plate	175.0	7.0
SG 52.4-D RK200.1 right with GLP5, mounted	052400020096	Right chain link including gliding plate	200.0	7.0
SG 52.4-D RK200.2 left with GLP5, mounted	052400020094	Left chain link including gliding plate	200.0	7.0
SG 52.4-D RK250.1 right with GLP5, mounted	052400025096	Right chain link including gliding plate	250.0	7.0
SG 52.4-D RK250.2 left with GLP5, mounted	052400025094	Left chain link including gliding plate	250.0	7.0
SG 52.4-D RK300.1 right with GLP5, mounted	052400030096	Right chain link including gliding plate	300.0	7.0
SG 52.4-D RK300.2 left with GLP5, mounted	052400030094	Left chain link including gliding plate	300.0	7.0

TR 52 SEPARATOR

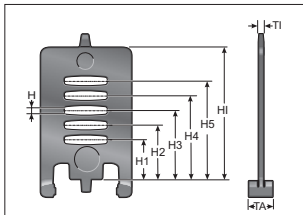

Separator

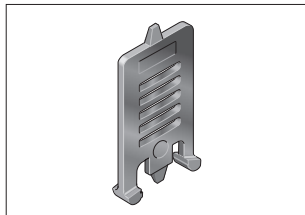

Separator

We recommend that separators be used if multiple round cables or conduits with differing diameters are to be installed. The closed separator is used when no shelves are used. This is the recommended design for travel paths of 32.81 yard or greater.

Type	Order No.	Description	Version	TI mm	TA mm	H mm	H1 mm	H2 mm	H3 mm	H4 mm	H5 mm	H1 mm
TR 52	052000009200	TR 52 Separator	lockable	3.5	10.0	4.2	16.3	22.3	28.2	33.8	39.8	52.0

TR 52.1 SEPARATOR

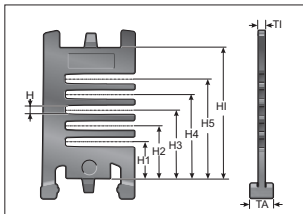

Separator

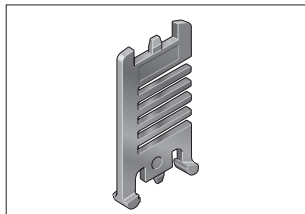

Separator

We recommend that separators be used if multiple round cables or conduits with differing diameters are to be installed.

Type	Order No.	Description	Version	TI mm	TA mm	H mm	H1 mm	H2 mm	H3 mm	H4 mm	H5 mm	H1 mm
TR 52.1	052100009200	TR 52.1 Separator	lockable	3.5	8.0	4.0	15.6	22.0	28.2	34.6	41.0	52.0

SEPARATOR TR 52-V

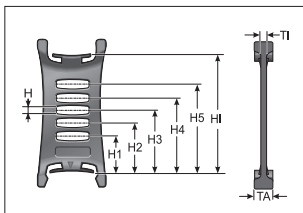

Separator

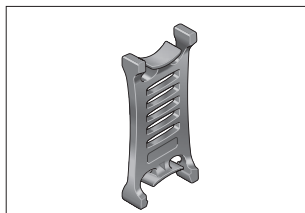

Separator

We recommend that separators be used if multiple round cables or conduits with differing diameters are to be installed.

Type	Order No.	Description	Version	TI mm	TA mm	H mm	H1 mm	H2 mm	H3 mm	H4 mm	H5 mm	H1 mm
TR 52-V	052000009300	TR 52-V Separator	movable	3.5	13.0	4.0	16.3	22.3	28.2	33.8	39.8	52.0

RTT 52 SHELF SUPPORT DIVISIBLE

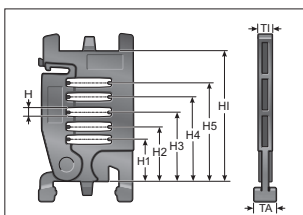

Shelf support

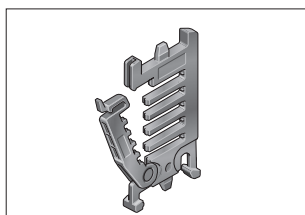

Shelf support

In connection with two separable shelf supports (RTT) with at least one end-to-end shelf (RB) the shelf becomes an easy to fill shelving system. The additional levels prevent cables from criss-crossing and minimize the friction between them.

Type	Order No.	Description	Version	TI mm	TA mm	H mm	H1 mm	H2 mm	H3 mm	H4 mm	H5 mm	H1 mm
RTT 52	100090522000	Shelf support divisible	lockable	7.0	8.0	4.0	15.6	22.0	28.2	34.6	41.0	52.0

RB-5 SHELF

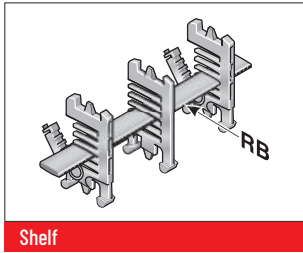

The shelf RBD creates a horizontal division over the entire inner width of the chain link. When used together with the TRT separator, an additional vertical division can be realized.

Type	Order No.	Description	Width mm	for inside width mm
RB 028-5	10000002800	Shelf	28.0	45.0
RB 034-5	1000003405	Shelf	33.6	45.0
RB 039-5	1000003905	Shelf	39.2	45.0
RB 045-5	1000004505	Shelf	44.8	57.0
RB 050-5	1000005005	Shelf	50.4	57.0
RB 056-5	10000005601	Shelf	56.0	62.0
RB 062-5	1000006205	Shelf	61.6	62.0
RB 067-5	1000006705	Shelf	67.2	84.0
RB 073-5	1000007305	Shelf	72.8	84.0
RB 078-5	1000007805	Shelf	78.4	84.0
RB 084-5	10000008400	Shelf	84.0	84.0
RB 090-5	1000009005	Shelf	89.6	96.0
RB 095-5	1000009505	Shelf	95.2	96.0
RB 101-5	1000010105	Shelf	100.8	107.0
RB 106-5	1000010605	Shelf	106.4	107.0
RB 112-5	100000011200	Shelf	112.0	121.0
RB 118-5	1000011805	Shelf	117.6	121.0
RB 123-5	1000012305	Shelf	123.2	133.0
RB 129-5	1000012905	Shelf	128.8	133.0
RB 134-5	1000013405	Shelf	134.4	144.0
RB 140-5	100000014000	Shelf	140.0	144.0
RB 146-5	1000014605	Shelf	145.6	158.0
RB 151-5	1000015105	Shelf	151.2	158.0
RB 157-5	1000015705	Shelf	156.8	164.0
RB 162-5	1000016205	Shelf	162.4	164.0
RB 168-5	100000016800	Shelf	168.0	182.0
RB 174-5	1000017405	Shelf	173.6	182.0
RB 179-5	1000017905	Shelf	179.2	196.0
RB 185-5	1000018505	Shelf	184.8	196.0
RB 190-5	1000019005	Shelf	190.4	196.0

RB-5 SHELF

Type	Order No.	Description	Width mm	for inside width mm
RB 196-5	10000019600	Shelf	196.0	196.0
RB 201-5	1000020105	Shelf	202.3	346.0
RB 207-5	1000020705	Shelf	207.8	346.0
RB 213-5	1000021305	Shelf	213.6	346.0
RB 218-5	1000021805	Shelf	219.2	346.0
RB 224-5	1000022405	Shelf	224.8	346.0
RB 229-5	1000022905	Shelf	230.4	346.0
RB 235-5	1000023505	Shelf	236.0	346.0
RB 241-5	1000024105	Shelf	241.8	346.0
RB 246-5	1000024605	Shelf	247.2	346.0
RB 252-5	1000025205	Shelf	252.9	346.0
RB 257-5	1000025705	Shelf	258.6	346.0
RB 263-5	1000026305	Shelf	264.0	346.0
RB 269-5	1000026905	Shelf	269.7	346.0
RB 274-5	1000027405	Shelf	274.4	346.0
RB 280-5	1000028005	Shelf	281.0	346.0
RB 285-5	1000028505	Shelf	285.0	346.0
RB 291-5	10000029100	Shelf	291.2	346.0

MP 52.4 OPEN / MP 52.4 CLOSED

MP 52/62/72 LOCK BUTTON

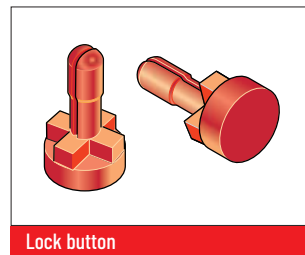
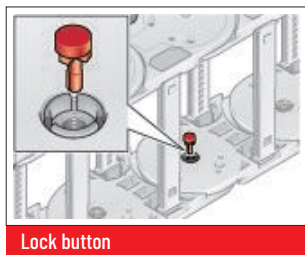
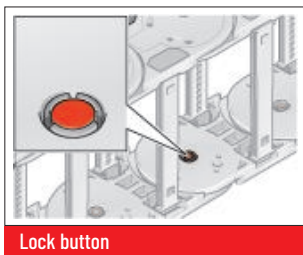

To increase the side stability we recommend the use of lock buttons during strong lateral acceleration or when installed "laying on the side

(turned 90°) without support".

Type	Order No.
MP52/62/72 lock button	0520000080

CROSSBAR CONNECTOR RSV 52

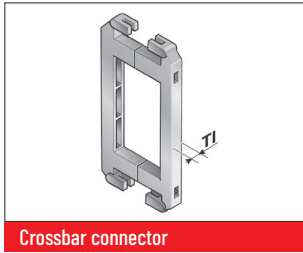

Crossbar connector

For crossbars wider than 246 mm, we recommend the use of crossbar connectors. These prevent deformation to the crossbar under large amounts of additional weight of the chain assembly.

Type	Order No.	Description	T1 mm
RSV 52	052000009600	Crossbar connector	7.5
RSV 52 Alu	052000009800	Crossbar connector for aluminum crossbars	7.5

RE 52 H-SHAPED SHELF UNIT

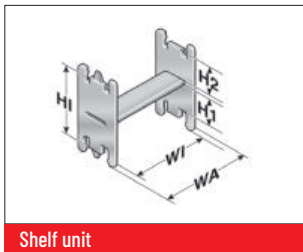

Shelf unit

One-piece shelving system, the shelf cannot be varied in height.

Type	Order No.	Description	WA mm	WI mm	H1 mm	H2 mm	HI mm
RE 36/17	100000361714	H-shaped shelf unit	42.5	36.5	31.0	17.4	52.0
RE 59/24	100000592414	H-shaped shelf unit	65.0	59.0	24.2	24.2	52.0
RE 81/12	100000811214	H-shaped shelf unit	87.5	81.5	36.0	12.4	52.0

BS-5 BRACKET BAR



Large-diameter conduits are routed securely by using bracket bars (BS). The bracket bar can be installed on both the inside or outside bend.

The bracket bar support (BSH) is used to attach the bars to PowerLine series crossbars. Two bracket bar supports are required for each bar. The mounting on the aluminum or plastic covers or on the crossbars of the HeavyLine series is carried out with the help of the mounting set bracket bar RS-5/RS-7. One mounting set is required per bracket bar.

Type	Order No.	Description	Conduit diameter max. mm	Installation height mm	Inner chain width min. mm
BS 120-5	052412000000	Bracket bar	115.0	140.0	164.0
BS 153-5	052415300000	Bracket bar	148.0	170.0	208.0
BS 187-5	052418700000	Bracket bar	182.0	205.0	233.0
BSH-5	052400000000	Bracket bar support			
Assembly set for bracket bar	052400000001	Assembly set for bracket bar			

CHAIN BRACKET COVER D4

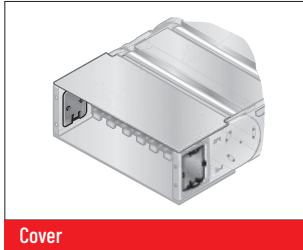

Cover

Self-locking covers close the side mounting window on the flexible chain bracket (KA-FB/FG).

Type	Order No.
D4 Cover	0413888002

RS-ZL-5 CROSSBAR STRAIN RELIEF

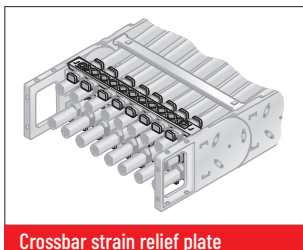

Crossbar strain relief plate

Fixed integrated crossbar strain relief plates in the chain brackets. Tailored to all crossbars widths up to 246 mm. May be assembled on the inside and outside bends at both chain endings.

Type	Order No.	Description	for inside width mm
RS-ZL 045-5	052004500010	Crossbar strain relief plate	45.0
RS-ZL 057-5	052005700010	Crossbar strain relief plate	57.0
RS-ZL 062-5	052006200010	Crossbar strain relief plate	62.0
RS-ZL 071-5	052007100010	Crossbar strain relief plate	71.0
RS-ZL 084-5	052008400010	Crossbar strain relief plate	84.0
RS-ZL 093-5	052009300010	Crossbar strain relief plate	93.0
RS-ZL 096-5	052009600010	Crossbar strain relief plate	96.0
RS-ZL 104-5	052010400010	Crossbar strain relief plate	104.0
RS-ZL 107-5	052010700010	Crossbar strain relief plate	107.0
RS-ZL 121-5	052012100010	Crossbar strain relief plate	121.0
RS-ZL 133-5	052013300010	Crossbar strain relief plate	133.0
RS-ZL 144-5	052014400010	Crossbar strain relief plate	144.0
RS-ZL 146-5	052014600010	Crossbar strain relief plate	146.0
RS-ZL 158-5	052015800010	Crossbar strain relief plate	158.0
RS-ZL 164-5	052016400010	Crossbar strain relief plate	164.0
RS-ZL 171-5	052017100010	Crossbar strain relief plate	171.0
RS-ZL 182-5	052018200010	Crossbar strain relief plate	182.0
RS-ZL 196-5	052019600010	Crossbar strain relief plate	196.0
RS-ZL 208-5	052020800010	Crossbar strain relief plate	208.0
RS-ZL 220-5	052022000010	Crossbar strain relief plate	220.0
RS-ZL 233-5	052023300010	Crossbar strain relief plate	233.0
RS-ZL 246-5	052024600010	Crossbar strain relief plate	246.0

MP 52.4 OPEN / MP 52.4 CLOSED

Product information

Steel Fix bow clamps for secure strain relief of cables at the C-rail at high accelerations, loads and long travel distances. The specification of the total height is indicative.

The actual height is, amongst other things, dependent on the diameter and the quality of the cable. A safety distance of 10 mm at the fixed point above the strain relief must be kept during gliding applications.

- Up to 3 cables on top of each other
- Suitable for C-rails with a groove width of 11 mm
- Plastic channels in specially developed design for strain relief that is gentle on cables
- May be assembled on the inside and outside bends at both ends of the energy chain

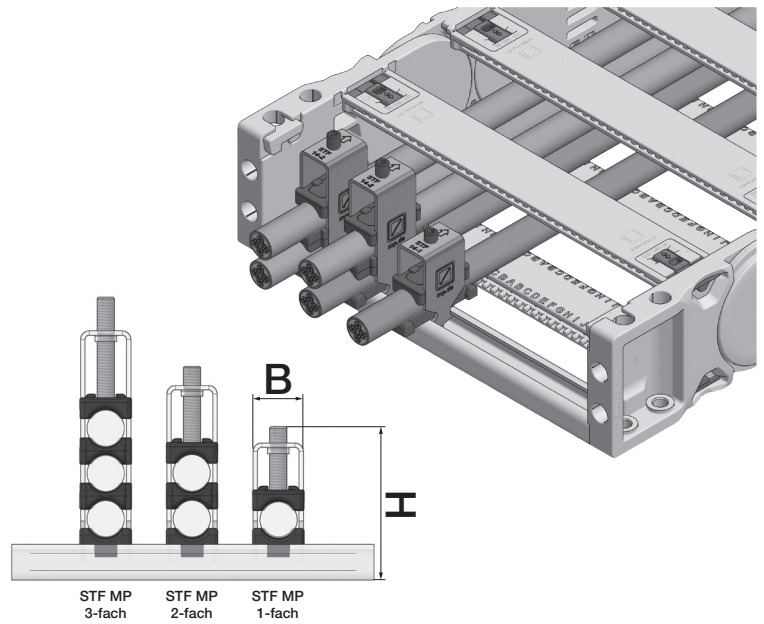

Type	Order No.	Description	Holders pieces	Cable Ø mm	Width (B) mm	Total height (H) mm
Single clamp (for one cable)						
STF MP 12-1 Steel Fix	80661801	Bow clamp	1	6 – 12	16	53
STF MP 14-1 Steel Fix	80661802	Bow clamp	1	12 – 14	18	53
STF MP 16-1 Steel Fix	80661803	Bow clamp	1	14 – 16	20	55
STF MP 18-1 Steel Fix	80661804	Bow clamp	1	16 – 18	22	57
STF MP 20-1 Steel Fix	80661805	Bow clamp	1	18 – 20	24	60
STF MP 22-1 Steel Fix	80661806	Bow clamp	1	20 – 22	26	62
STF MP 26-1 Steel Fix	80661807	Bow clamp	1	22 – 26	30	70
STF MP 30-1 Steel Fix	80661808	Bow clamp	1	26 – 30	34	74
STF MP 34-1 Steel Fix	80661809	Bow clamp	1	30 – 34	38	78
STF MP 38-1 Steel Fix	80661810	Bow clamp	1	34 – 38	42	82
STF MP 42-1 Steel Fix	80661811	Bow clamp	1	38 – 42	46	87
Double clamp (for two cables)						
STF MP 12-2 Steel Fix	80661821	Bow clamp	2	6 – 12	16	73
STF MP 14-2 Steel Fix	80661822	Bow clamp	2	12 – 14	18	74
STF MP 16-2 Steel Fix	80661823	Bow clamp	2	14 – 16	20	81
STF MP 18-2 Steel Fix	80661824	Bow clamp	2	16 – 18	22	85
STF MP 20-2 Steel Fix	80661825	Bow clamp	2	18 – 20	24	89
STF MP 22-2 Steel Fix	80661826	Bow clamp	2	20 – 22	26	93
STF MP 26-2 Steel Fix	80661827	Bow clamp	2	22 – 26	30	110
STF MP 30-2 Steel Fix	80661828	Bow clamp	2	26 – 30	34	118
STF MP 34-2 Steel Fix	80661829	Bow clamp	2	30 – 34	38	126
Triple clamp (for three cables)						
STF MP 12-3 Steel Fix	80661841	Bow clamp	3	6 – 12	16	96
STF MP 14-3 Steel Fix	80661842	Bow clamp	3	12 – 14	18	100
STF MP 16-3 Steel Fix	80661843	Bow clamp	3	14 – 16	20	106
STF MP 18-3 Steel Fix	80661844	Bow clamp	3	16 – 18	22	113
STF MP 20-3 Steel Fix	80661845	Bow clamp	3	18 – 20	24	120
STF MP 22-3 Steel Fix	80661846	Bow clamp	3	20 – 22	26	126

Product information

Compact strain relief for pneumatic hoses and signal cables. The specification of the total height is indicative. The actual height is, amongst other things, dependent on the diameter and the quality of the cable. A safety distance of 10 mm at the fixed point above the strain relief must be kept during gliding applications.

- For 2 cables side by side with max. Ø 7 mm
- Up to 4 cables on top of each other
- Suitable for C-rails with a groove width of 11 mm
- Plastic channels in specially developed design for strain relief that is gentle on cables
- May be assembled on the inside and outside bends at both ends of the energy chain

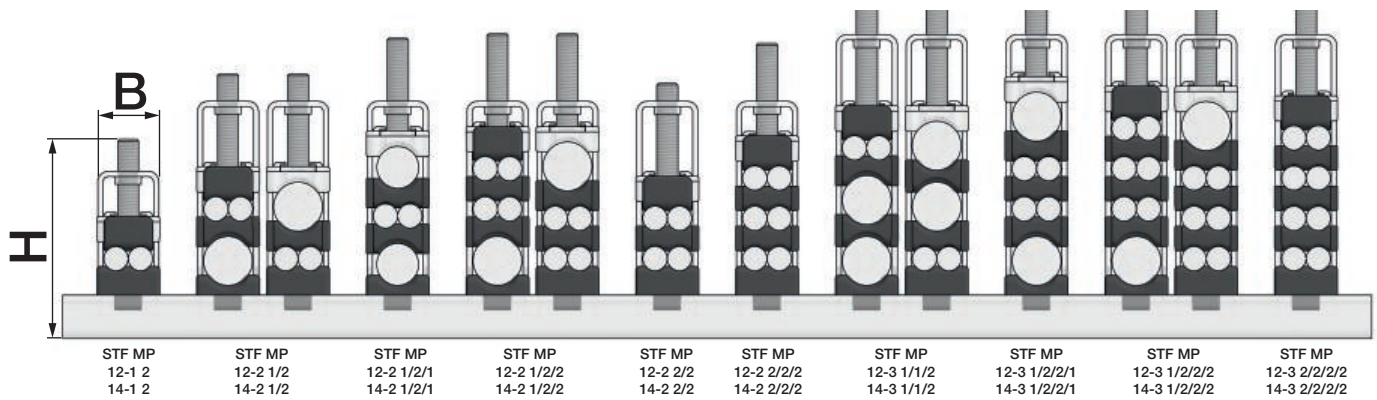
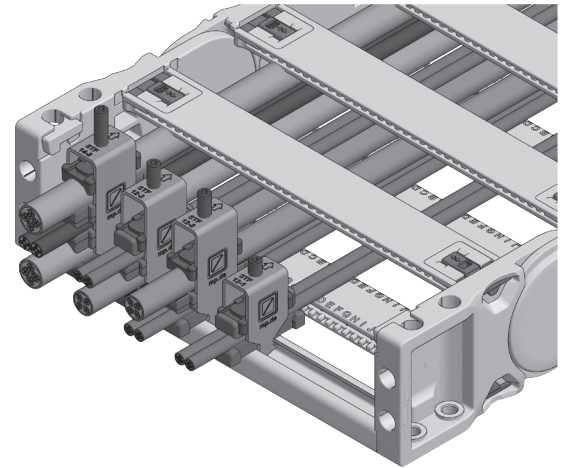

MP 52.4-OPEN / MP 52.4 CLOSED

Type	Order No.	Description	Holders pieces	Cable Ø 2 x / 1 x mm	Width (B) mm	Total height (H) mm
Bow clamp multiple size 12 (for two cables side by side)						
STF MP 12-1 2	80662001	Bow clamp	2	3-6 / -	16	54
STF MP 12-2 1/2	80662025	Bow clamp	3	3-6 / 6-12	16	74
STF MP 12-2 1/2/1	80662029	Bow clamp	4	3-6 / 6-10	16	83
STF MP 12-2 1/2/2	80662027	Bow clamp	5	3-6 / 6-12	16	73
STF MP 12-2 2/2	80662021	Bow clamp	4	3-6 / -	16	70
STF MP 12-2 2/2/2	80662023	Bow clamp	6	3-6 / -	16	80
STF MP 12-3 1/1/2	80662045	Bow clamp	4	3-6 / 6-12	16	97
STF MP 12-3 1/2/2/1	80662047	Bow clamp	6	3-6 / 6-12	16	104
STF MP 12-3 1/2/2/2	80662043	Bow clamp	7	3-6 / 6-12	16	101
STF MP 12-3 2/2/2/2	80662041	Bow clamp	8	3-6 / -	16	97
Bracket clamp multiple size 14 (for two cables side by side)						
STF MP 14-1 2	80662002	Bow clamp	2	5-7 / -	18	57
STF MP 14-2 1/2	80662026	Bow clamp	3	5-7 / 12-14	18	76
STF MP 14-2 1/2/1	80662030	Bow clamp	4	5-7 / 12	18	86
STF MP 14-2 1/2/2	80662028	Bow clamp	5	5-7 / 12-14	18	87
STF MP 14-2 2/2	80662022	Bow clamp	4	6-7 / -	18	73
STF MP 14-2 2/2/2	80662024	Bow clamp	6	5-7 / 12-14	18	85
STF MP 14-3 1/1/2	80662046	Bow clamp	4	5-7 / 12-14	18	104
STF MP 14-3 1/2/2/1	80662048	Bow clamp	6	5-7 / 12-14	18	112
STF MP 14-3 1/2/2/2	80662044	Bow clamp	7	5-7 / 12-14	18	109
STF MP 14-3 2/2/2/2	80662042	Bow clamp	8	5-7 / -	18	107

LOWERED MOVING END BRACKET MP 52.4

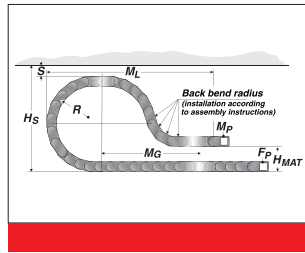
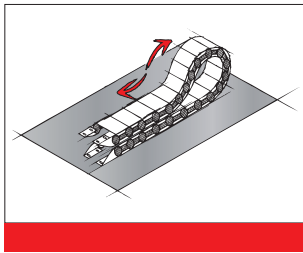

It is sometimes necessary to lower the height of the moving end bracket.

In such cases, modifications to the chain layout should be noted (e.g. extension of chain).

Please contact our application engineers.

Radius R mm	Height of moving end bracket (H_{NA}) mm	Safety margin (S) mm	Installation height incl. safety (H_S) mm	Projection (M_L) mm	Additional links pcs.	of which additional rearward chain links pcs.
175.0	180.0	50.0	475.0	620.0	6	3
200.0	210.0	50.0	525.0	830.0	10	3
250.0	250.0	50.0	625.0	990.0	13	3
300.0	300.0	50.0	725.0	900.0	14	3

MP 52.4 REARWARD RADII

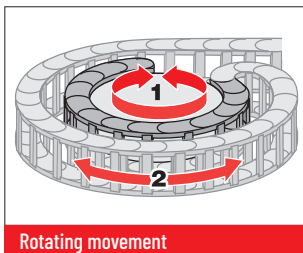

Rotating movement

Side links with rearward radius allow movements in both directions. This is intended for rotating movements and lowered chain brackets. Note: This type of chain has different chain links for the left or right side! Rotation movements are only possible with open variants.

Type	Order No.	Radius mm	Rearward radius mm
SR 52.4 (RÜ200/R200.1) right	052400020062	200.0	200.0
SR 52.4 (RÜ200/R200.2) left	052400020060	200.0	200.0

VAW GUIDE CHANNEL (ALUMINUM / STAINLESS STEEL)



VAW steel galvanized/stainless steel



VAW aluminum

A range of variable guide channel systems, constructed from aluminum or stainless steel sections, is available for this energy chain. The variable guide channel ensures that the energy chain is supported and guided securely.

ASSEMBLY

DISASSEMBLY

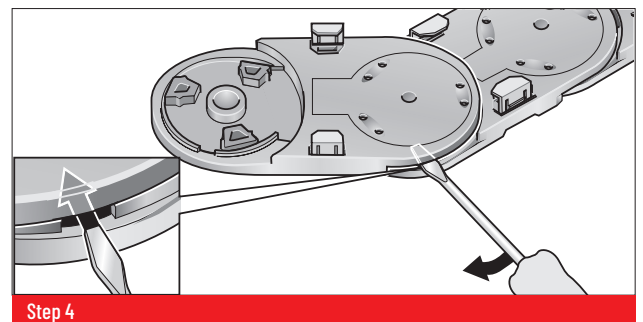
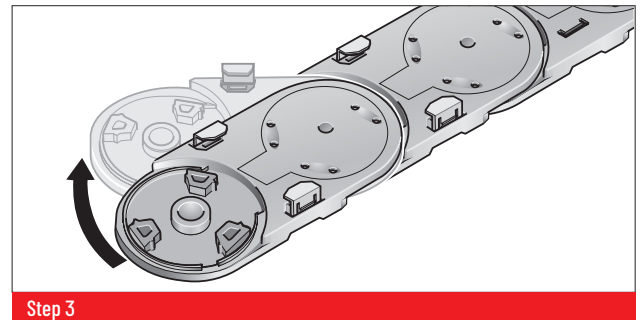
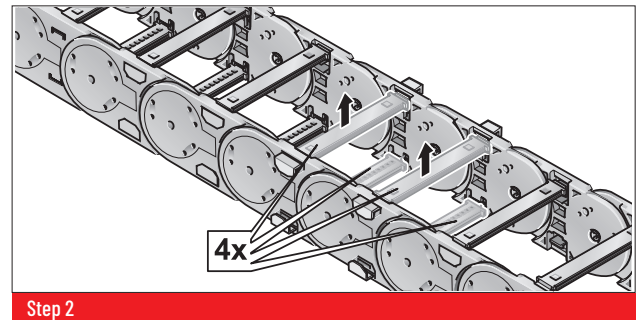
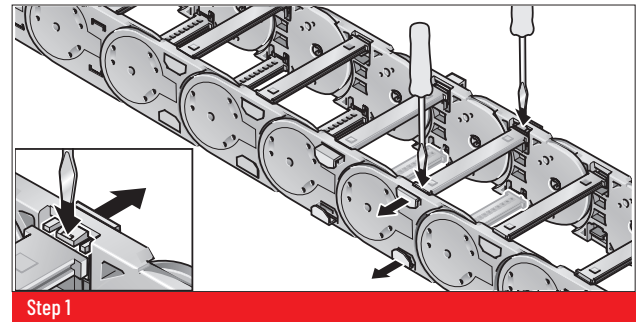
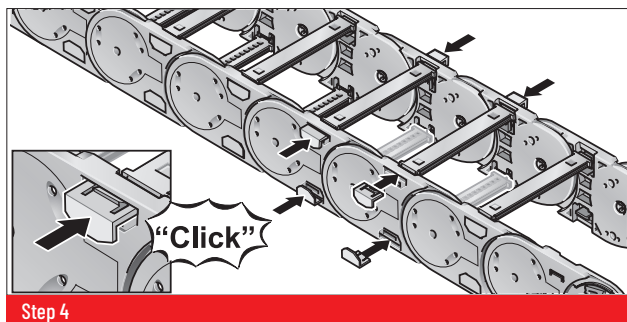
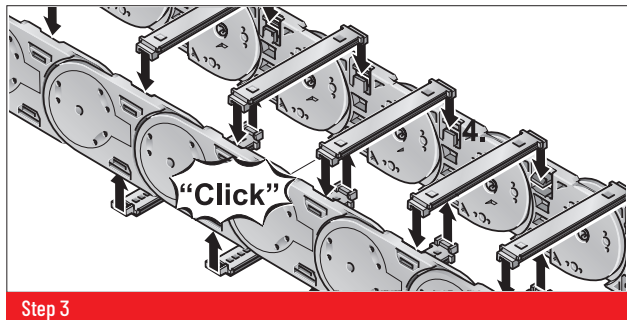
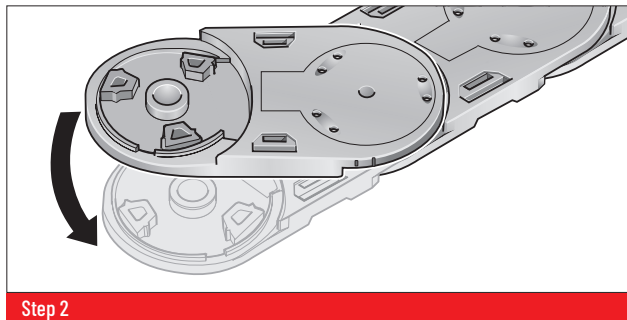
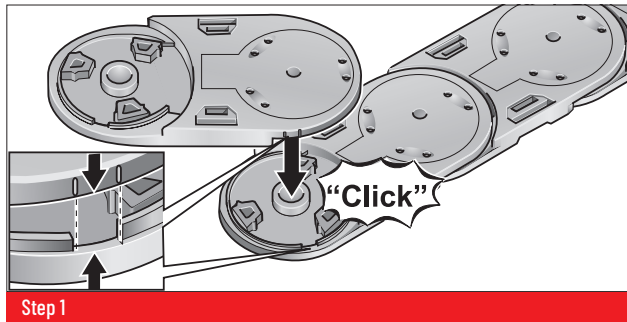

MP 52.4 OPEN / MP 52.4 CLOSED

All details given in our sales brochures and catalogs, as well as the information available online, are based on our current knowledge of the products described.
 The electronic data and files made available by murrplastik, particularly CAD files are based on our current knowledge of the products described.
 A legally binding assurance of certain properties or the suitability for a certain purpose can not be determined from this information.
 All information with respect to the chemical and physical properties of Murrplastik products, as well as application advice given verbally, in writing or by tests, is given to the best of our knowledge.
 They do not release the buyer from the obligation to carry out his own tests and trials in order to determine the concrete suitability of the products for the intended purpose.
 murrplastik accepts no responsibility for the available information being up-to-date, correct or complete. Neither do we accept responsibility for the quality of this information.
 murrplastik accepts no liability for damage caused as a result of using our products.
 murrplastik reserves the right to make technical changes and improvements through constant further development of products and services.
 Our General Terms and Conditions apply.



Murrplastik Systemtechnik GmbH

Dieselstraße 10
71570 Oppenweiler
Germany

+49 7191 482-0
info@murrplastik.de

HRB 271053
Local court Stuttgart
VAT ID: DE 144 744 122



More info at

murrplastik.de