



Cable drag chain systems

MP 35

MP 35

OPEN



- METAL CHAIN BRACKET
- LOW-COST VARIANT

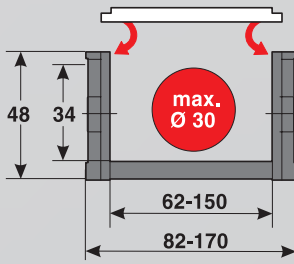

TECHNICAL DATA

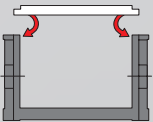

Loading side
Inside bend

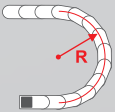

Available radii
70.0 – 300.0 mm

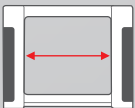

Available interior widths
With plastic frame bridge
62.0 – 150.0 mm

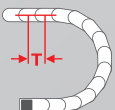

Pitch
T = 58.0 mm

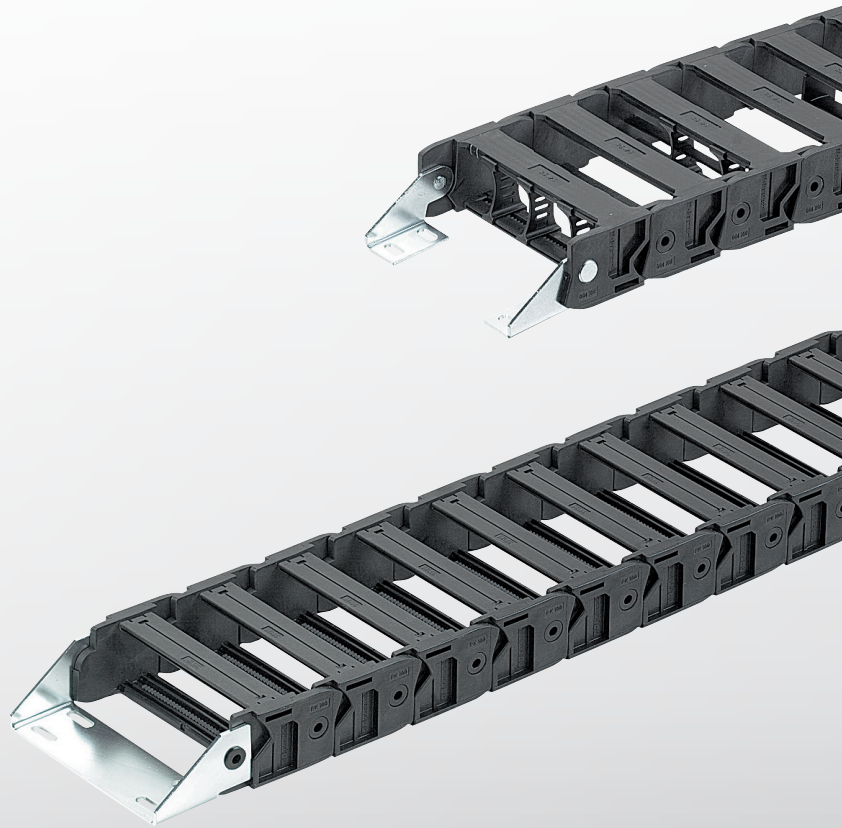



TECHNICAL SPECIFICATIONS

Travel distance gliding L_g max.	80.0 m
Travel distance self-supporting L_f max.	see diagram on page 5
Travel distance vertical, hanging L_{vh} max.	40.0 m
Travel distance vertical, upright L_{vs} max.	3.0 m
Rotated 90°, unsupported L_{90f} max.	1.0 m
Speed, gliding V_g max.	3.0 m/s
Speed, self-supporting V_f max.	10.0 m/s
Acceleration, gliding a_g max.	15.0 m/s ²
Acceleration, self-supporting a_f max.	20.0 m/s ²

Contact our engineering department to meet any higher requirements: efk@murrplastik.de

MATERIAL PROPERTIES

Standard material	Polyamide (PA) black
Service temperature	-30.0 – 120.0 °C
Gliding friction factor	0.3
Static friction factor	0.45
Fire classification	Based on UL 94 HB

Other material properties on request.

SHELVING SYSTEM

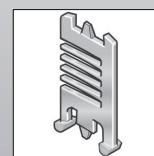

Separator TR

CHAIN BRACKET

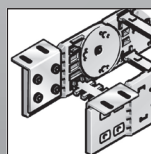

Chain bracket angle

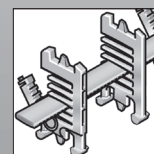

Shelving system RS

GUIDE CHANNELS

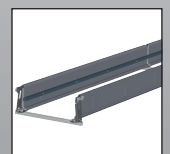

VAW stainless steel

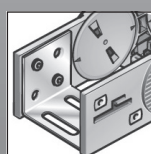

Chain bracket U-part

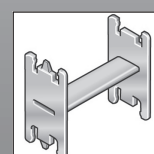

H-shaped shelf unit RE

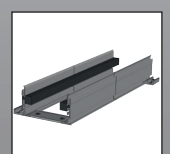

VAW aluminium

ORDERING KEY

Dimensions in mm [US inch]

Type code	Variation	Inside width	Outside width	Inside width	Outside width	Radius	Rail variant	Material	Chain length
0350 02	Frame bridge on outside of radius Frame bridge on inside bend Opens on inside of radius	062 [2.44]	082 [3.23]			070 [2.76]	0 Plastic, full-ridged with bias	0 Polyamide standard (PA/black)	
		086 [3.39]	106 [4.17]						
		102 [4.02]	122 [4.80]						
		125 [4.92]	145 [5.71]			100 [3.94]	1 Plastic, full-ridged without bias	9 Special version (on request)	
		150 [5.91]	170 [6.69]						
						150 [5.91]			
						200 [7.87]			
						300 [11.81]			

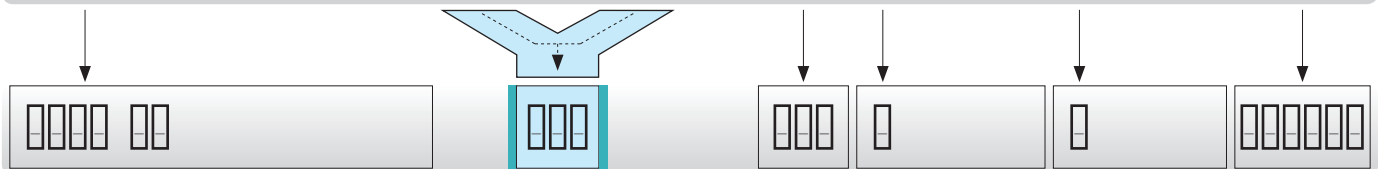

ORDER SAMPLE: 0350 02 062 070 0 0 1276

Frame bridge in outside bend, frame bridge in inside bend, can be opened from inside bend
 Inside width 62 mm; radius 70 mm
 Plastic bridge, full-ridged with bias, material black-coloured polyamide
 Chain length 1276 mm (22 links)

SELF-SUPPORTING LENGTH

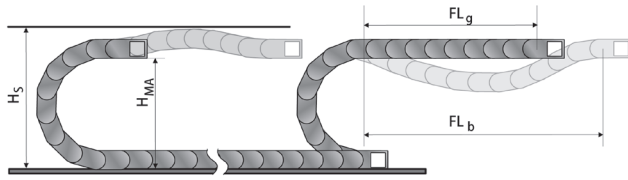

The self-supporting length is the distance between the chain bracket on the moving end and the start of the chain arch. The installation variant FL_g offers the lowest load and wear for the cable drag chain. The maximum travel parameters (speed and acceleration) can be applied for this variant.

- H_s = Installation height plus safety
- H_{MA} = Height of moving end connection
- FL_g = Self-supporting length, upper run straight
- FL_b = Self-supporting length, upper run bent

LOAD DIAGRAM FOR SELF-SUPPORTING APPLICATIONS

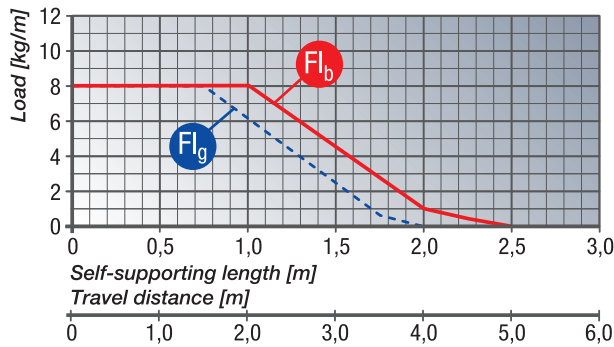

FL_g Self-supporting length, upper run straight
In the FL_g range, the chain upper run still has a bias, is straight or has a maximum sag of 60.0 mm.

FL_b Self-supporting length, upper run bent
In the FL_b range, the chain upper run has a sag of more than 60.0 mm, but this is still less than the maximum sag. Where the sag is greater than that permitted in the FL_b range, the application is critical and should be avoided. The self-supporting length can be optimized by using a support for the upper run or a more stable energy chain.

DETERMINING THE CHAIN LENGTH

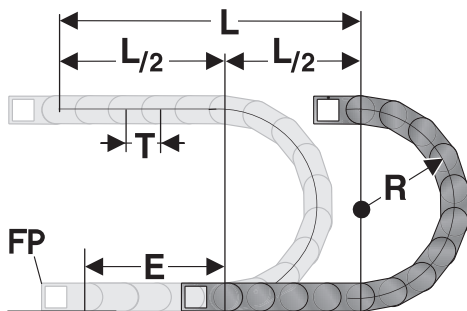

The fixed point of the cable drag chain should be connected in the middle of the travel distance. This arrangement gives the shortest connection between the fixed point and the moving consumer and thus the most efficient chain length.

Chain length calculation = $L/2 + \pi * R + 2 * T + E$
 $\approx 1 \text{ m chain} = 17 \text{ qty. x } 58.0 \text{ mm links.}$

- E = distance between entry point and middle of travel distance
- L = travel distance
- R = radius
- T = Pitch 58.0 mm

EINBAUMASSE

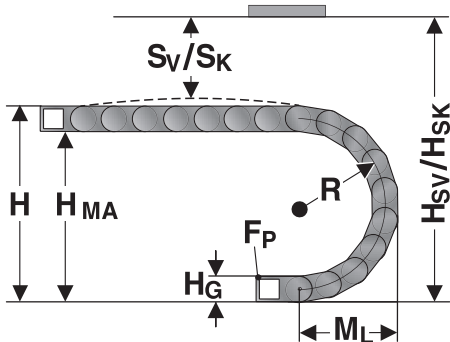

The moving end chain connection is to be screw fixed at height H_{MA} for the respective radius.

Concerning the installed dimensions, you must take into account whether the chain links are equipped with or without bias.

For chain links without bias, the „Installed height without bias H_{SK} “ value has to be taken into account.

If the chain links are equipped with a bias, the value „Installed height with bias H_{SV} “ has to be taken into account.

Radius R	70	100	150	200	300
Outside height of chain link (H_G)	48	48	48	48	48
Height of bend (H)	188	248	348	448	648
Height of moving end bracket (H_{MA})	140	200	300	400	600
Safety margin with bias (S_v)	40	40	40	40	40
Installation height with bias (H_{sv})	228	288	388	488	688
Safety margin without bias (S_k)	15	15	15	15	15
Installation height without bias (H_{sk})	203	263	363	463	663
Arc projection (M_L)	152	182	232	282	382

CHAIN BRACKET ANGLE KA 35

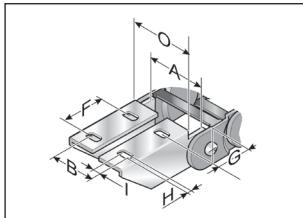

KA 35... (Inside up / down)

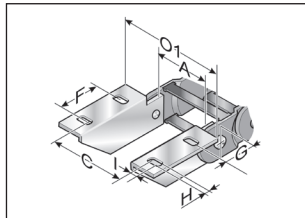

KA 35... (Outside up / down)

The chain bracket can be supplied either in galvanised sheet steel or stainless steel. To secure one cable drag chain, you will need two angle brackets (left and right) with a drilled hole and two angle brackets (left and right) with a bolt. The order numbers given below each comprise a left and right angle bracket.

Type	Order No.	Material	Inside width							Outside width KA	Outside width KA
			A mm	B mm	C mm	F mm	G mm	HØ mm	I mm		
KA 3508 Female end	0350000054	Sheet steel	62.0 – 150.0	A-7.0	A+28.0	25.0	20.0	7.0	8.0	A+20.0	A+52.0
KA 3508 Male end	0350000055	Sheet steel	62.0 – 150.0	A-12.0	A+38.5	25.0	20.0	7.0	8.0	A+10.0	A+52.0
KA 3509 Female end	0350000056	Stainless steel 1.4301	62.0 – 150.0	A-7.0	A+28.0	25.0	20.0	7.0	8.0	A+20.0	A+52.0
KA 3509 Male end	0350000057	Stainless steel 1.4301	62.0 – 150.0	A-12.0	A+38.5	25.0	20.0	7.0	8.0	A+10.0	A+52.0

CHAIN BRACKET U-PART KA 35

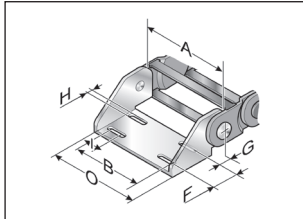

KA 35062 – 35150

The metal connection (U-section) is precisely adjusted to the respective chain width. It only needs to be snapped in the chain link. Please order one male and one female end bracket for each chain. The brackets should be fastened with M6 screws.

Type	Order No.	Material	Inside width						Outside width KA	
			A mm	B mm	F mm	G mm	HØ mm	I mm	O mm	
KA 35062 Female end	035000007000	Sheet steel	62.0	A-7.0	25.0	20.0	7.0	15.0	A+20.0	
KA 35062 Male end	035000007100	Sheet steel	62.0	A-12.0	25.0	20.0	7.0	15.0	A+20.0	
KA 35086 Female end	035000007200	Sheet steel	86.0	A-7.0	25.0	20.0	7.0	15.0	A+20.0	
KA 35086 Male end	035000007300	Sheet steel	86.0	A-12.0	25.0	20.0	7.0	15.0	A+20.0	
KA 35102 Female end	035000007400	Sheet steel	102.0	A-7.0	25.0	20.0	7.0	15.0	A+20.0	
KA 35102 Male end	035000007500	Sheet steel	102.0	A-12.0	25.0	20.0	7.0	15.0	A+20.0	
KA 35125 Female end	035000007600	Sheet steel	125.0	A-7.0	25.0	20.0	7.0	15.0	A+20.0	
KA 35125 Male end	035000007700	Sheet steel	125.0	A-12.0	25.0	20.0	7.0	15.0	A+20.0	
KA 35150 Female end	035000007800	Sheet steel	150.0	A-7.0	25.0	20.0	7.0	15.0	A+20.0	
KA 35150 Male end	035000007900	Sheet steel	150.0	A-12.0	25.0	20.0	7.0	15.0	A+20.0	
KA 35062 Female end	035000008000	Stainless steel 1.4301	62.0	A-7.0	25.0	20.0	7.0	15.0	A+20.0	
KA 35062 Male end	035000008100	Stainless steel 1.4301	62.0	A-12.0	25.0	20.0	7.0	15.0	A+20.0	
KA 35086 Female end	035000008200	Stainless steel 1.4301	86.0	A-7.0	25.0	20.0	7.0	15.0	A+20.0	
KA 35086 Male end	035000008300	Stainless steel 1.4301	86.0	A-12.0	25.0	20.0	7.0	15.0	A+20.0	
KA 35102 Female end	035000008400	Stainless steel 1.4301	102.0	A-7.0	25.0	20.0	7.0	15.0	A+20.0	
KA 35102 Male end	035000008500	Stainless steel 1.4301	102.0	A-12.0	25.0	20.0	7.0	15.0	A+20.0	
KA 35125 Female end	035000008600	Stainless steel 1.4301	125.0	A-7.0	25.0	20.0	7.0	15.0	A+20.0	
KA 35125 Male end	035000008700	Stainless steel 1.4301	125.0	A-12.0	25.0	20.0	7.0	15.0	A+20.0	
KA 35150 Female end	035000008800	Stainless steel 1.4301	150.0	A-7.0	25.0	20.0	7.0	15.0	A+20.0	
KA 35150 Male end	035000008900	Stainless steel 1.4301	150.0	A-12.0	25.0	20.0	7.0	15.0	A+20.0	

SEPARATOR TR 35

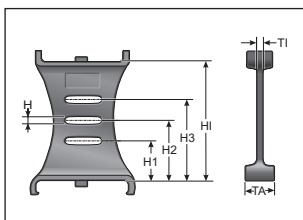

Separator

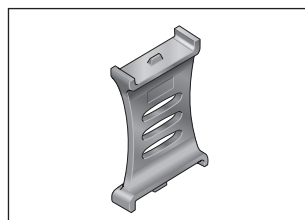

We recommend that separators be used if multiple round cables or conduits with differing diameters are to be installed.

Type	Order No.	Designation	Version	TI mm	TA mm	H mm	H1 mm	H2 mm	H3 mm	HI mm
TR 35	035000009200	Separator	lockable	2.0	13.0	2.5	10.9	16.9	22.9	33.8

SHELVING SYSTEM MP 35

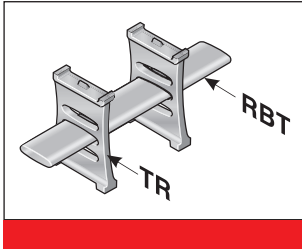

The shelf must be used with a minimum of two separators to create a shelving system. The additional levels prevent cables from criss-crossing and minimise the friction between them. The shelves are matched to the available chain widths.

Type	Order No.	Designation	Width mm	Pitch mm
RBT 062	100000006200	Shelf	62.0	3.03.0
RBT 086	100000008600	Shelf	86.0	3.03.0
RBT 101	100000010100	Shelf	101.0	3.03.0
RBT 125	100000012500	Shelf	125.0	3.03.0
RBT 150	100000015000	Shelf	150.0	3.03.0

RE 35 H-SHAPED SHELF UNIT

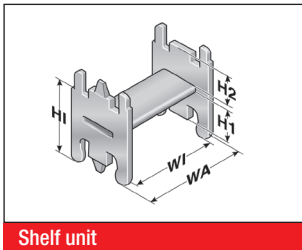

Shelf unit

One-piece shelving system, the shelf cannot be varied in height.

Type	Order No.	Designation	WA mm	WI mm	H1 mm	H2 mm	HI mm
RE 35/33	100000353310	H-shaped shelf unit	35.5	30.5	18.0	12.0	33.0
RE 35/48	100000354810	H-shaped shelf unit	50.5	45.5	18.0	12.0	33.0
RE 35/57	100000355710	H-shaped shelf unit	59.5	54.5	18.0	12.0	33.0

GUIDE CHANNEL VAW (ALUMINIUM / STAINLESS STEEL)



VAW aluminium



VAW stainless steel

For this cable drag chain, a range of variable guide channel systems are available, constructed from aluminium or stainless steel sections.

The variable guide channel ensures that the cable drag chain is supported and guided securely.

For help on choosing, please consult the chapter „Variable Guide Channel System“.

ASSEMBLY

DISASSEMBLY

MP 35 OPEN

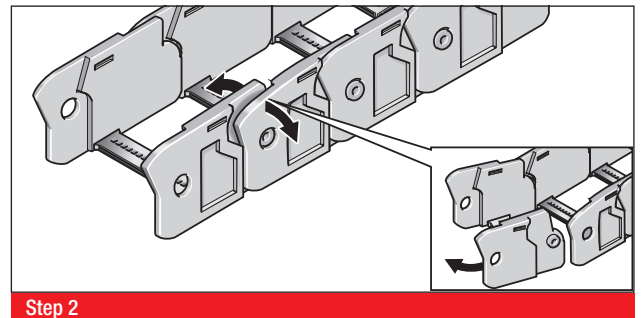
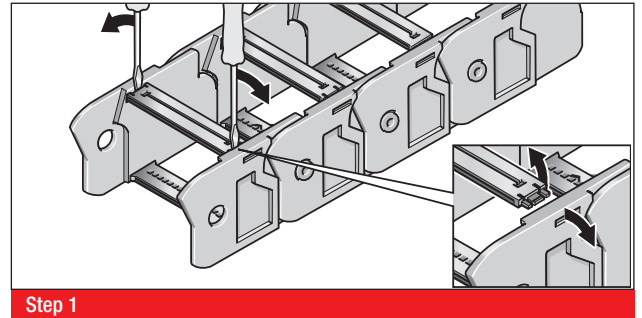
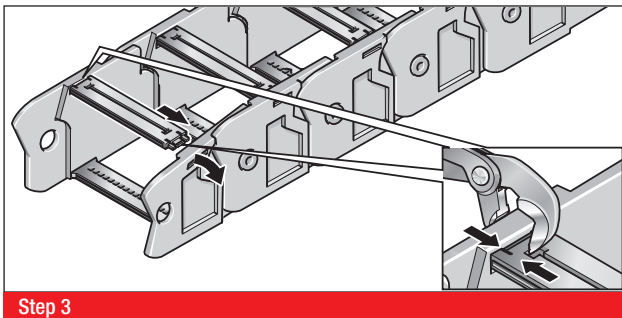
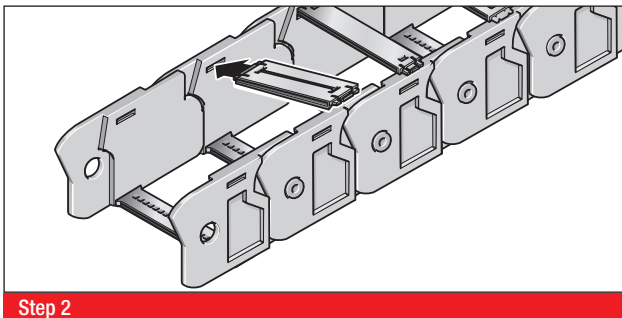
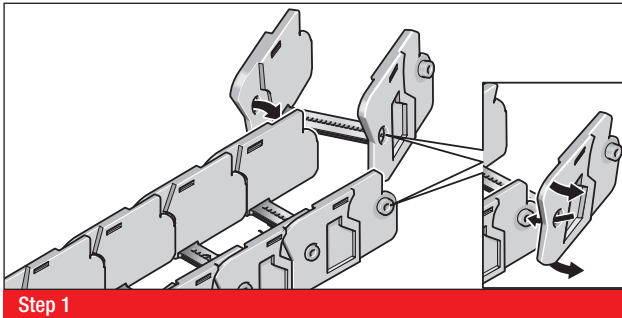

All details given in our sales material prospectuses and catalogues as well as the information available online are based on our current knowledge of the products described.
 The electronic data and files made available by Murrplastik, particularly CAD files are based on our current knowledge of the product described.
 A legally binding assurance of certain properties or the suitability for a certain purpose can not be determined from this information.
 All information with respect to the chemical and physical properties of Murrplastik products as well as application advice given verbally, in writing or by tests, is given to the best of our knowledge.
 This does not free the purchaser of carrying out their own inspections and tests in order to determine the suitability of a product for a specific purpose.
 Murrplastik accepts no responsibility for the available information being up-to-date, correct or complete. Neither do we accept responsibility for the quality of this information.
 Murrplastik accepts no liability for damage caused as a result of using our products.
 Murrplastik reserves the right to make technical changes and improvements through constant further development of products and services.
 Our General Terms and Conditions apply.