



# Cable drag chain systems

## MP 52.2, MP 52.3

**6 new frame bridges  
made from plastic**

**Internal widths:  
57 mm, 93 mm,  
104 mm, 164 mm,  
208 mm, 233 mm**

# MP 52.2

OPEN

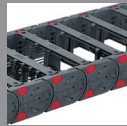

# MP 52.3

CLOSED



- SLIDING BLOCKS FOR LONGER SERVICE LIFE
- BROAD INTERIOR LAYOUT
- FLEXIBLE CHAIN BRACKET
- PLASTIC OR ALUMINIUM VERSION

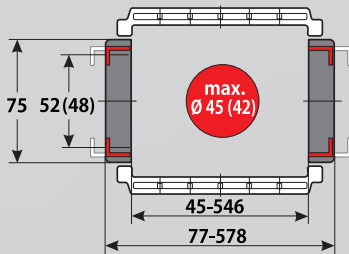

## TECHNICAL DATA

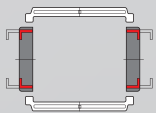

**Loading side**  
Inside and outside bend

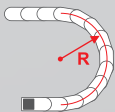

**Available radii**  
100.0 – 350.0 mm

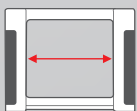

**Available interior widths**  
With plastic frame bridge  
45.0 – 546.0 mm  
With Alu frame bridge / With Alu cover  
67.0 – 600.0 mm / 43.0 – 600.0 mm

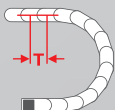

**Pitch**  
T = 91.0 mm

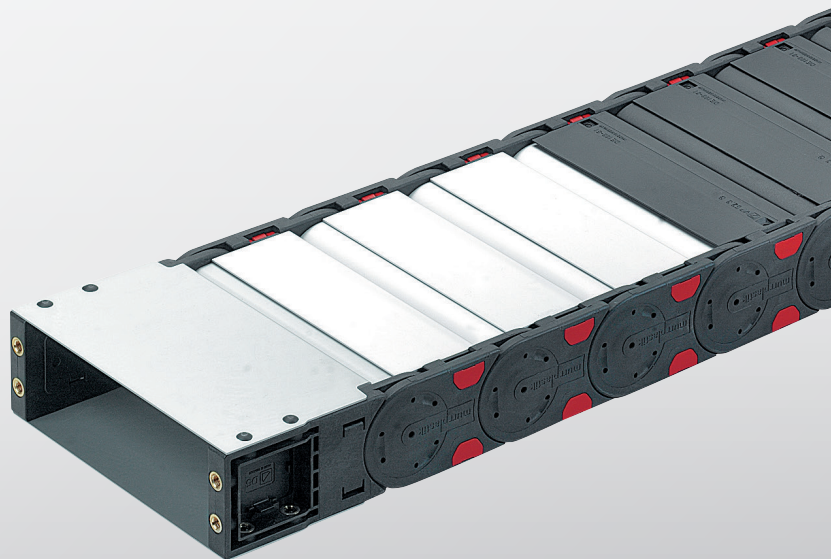
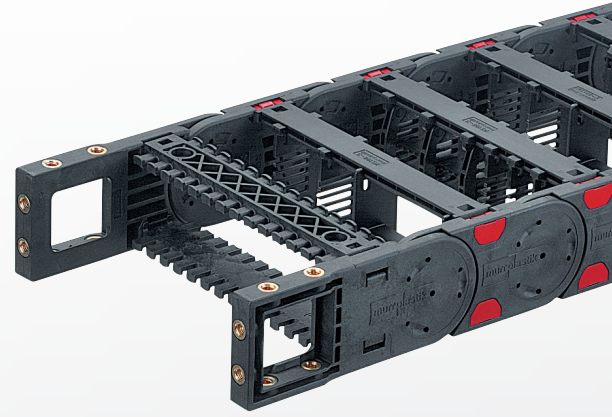

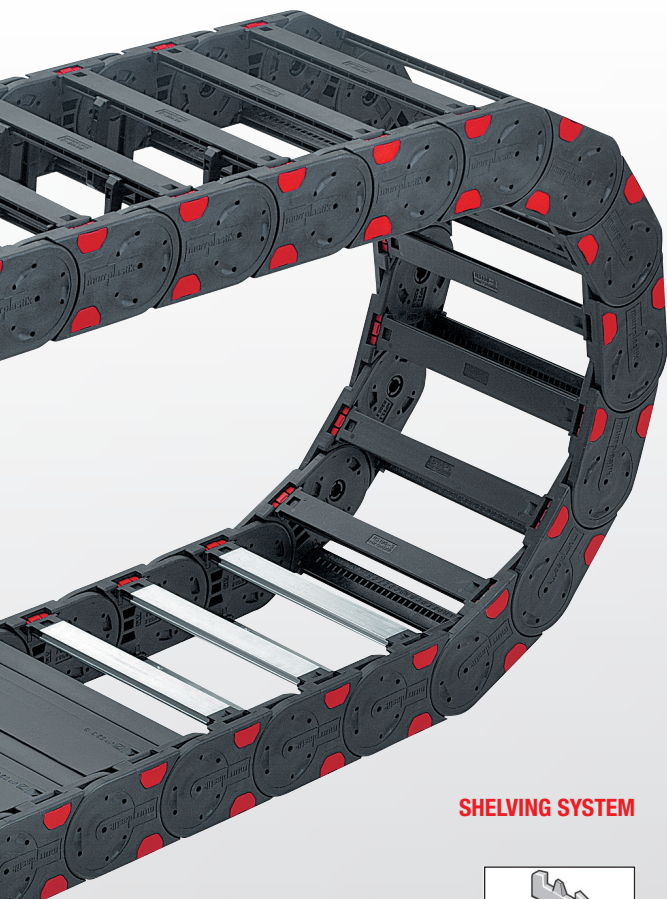

## TECHNICAL SPECIFICATIONS

Travel distance gliding $L_g$ max.	150.0 m
Travel distance self-supporting $L_s$ max.	see diagram on page 5
Travel distance vertical, hanging $L_{vh}$ max.	60.0 m
Travel distance vertical, upright $L_{vs}$ max.	6.0 m
Rotated 90°, unsupported $L_{90f}$ max.	2.0 m
Speed, gliding $V_g$ max.	5.0 m/s
Speed, self-supporting $V_s$ max.	20.0 m/s
Acceleration, gliding $a_g$ max.	25.0 m/s <sup>2</sup>
Acceleration, self-supporting $a_s$ max.	30.0 m/s <sup>2</sup>

Contact our engineering department to meet any higher requirements: [efk@murrplastik.de](mailto:efk@murrplastik.de)

## MATERIAL PROPERTIES

Standard material	Polyamide (PA) black
Service temperature	-30.0 – 120.0 °C
Gliding friction factor	0.3
Static friction factor	0.45
Fire classification	UL 94 HB

Other material properties on request.

### SHELVING SYSTEM

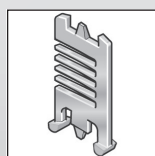

Separator TR

### ACCESSORIES

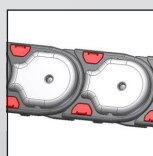

Slide plate

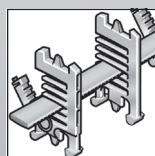

Shelving system RS



Extender frame bridge

### CHAIN BRACKET

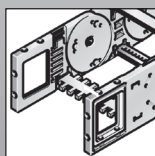

Chain bracket flexible

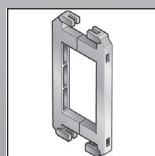

Frame bridge connector RSV

### GUIDE CHANNELS

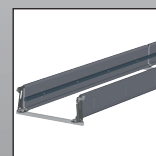

VAW stainless steel

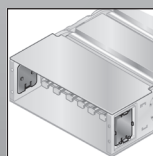

Cover

### STRAIN RELIEF

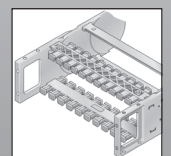

RS-ZL frame rail

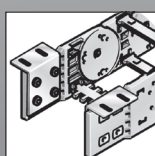

Chain bracket angle

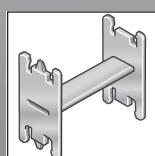

H-shaped shelf unit RE

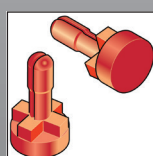

Lock button

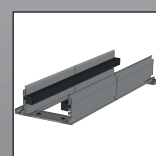

VAW aluminium

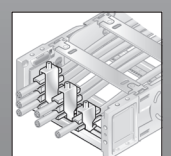

STF Steel Fix

ORDERING KEY

Dimensions in mm [US inch]

Type code	Variation	Inside width	Outside width	Inside width	Outside width	Radius	Rail variant	Material	Chain length
0522 30	MP 52.2 open Frame bridge on outside of radius Frame bridge on inside bend Opens on inside and outside of radius	045 <sup>1)</sup> [1.77]	077 [3.03]	233 [9.17]	265 [10.43]	100 <sup>1)</sup> [3.94]	0 Plastic, full-ridged with bias	0 Polyamide standard (PA/black)	
		057 <sup>1)</sup> [2.24]	089 [3.50]	246 <sup>2)</sup> [9.69]	278 <sup>2)</sup> [10.94]				
0523 44 <sup>3)</sup>	MP 52.3 Closed Cover on outside of radius Cover on inside of radius Opens on inside and outside of radius	062 <sup>1)</sup> [2.44]	094 [3.70]	252 [9.92]	284 [11.18]	150 [5.91]	1 Plastic, full-ridged without bias	5 Polypropylene (PP/blue)	
		071 [2.80]	103 [4.06]	258 [10.16]	290 [11.42]				
		084 [3.31]	116 [4.57]	296 <sup>2)</sup> [11.65]	328 <sup>2)</sup> [12.91]	175 [6.89]	2 Plastic, half-ridged with bias	7 EMC (PA/light grey)	
		093 [3.66]	125 [4.92]	346 <sup>2)</sup> [13.62]	378 <sup>2)</sup> [14.88]				
		096 <sup>2)</sup> [3.78]	128 <sup>2)</sup> [5.04]	350 [13.78]	382 [15.04]	200 [7.87]	3 Plastic, half-ridged without bias	9 Special version (on request)	
		104 [4.09]	136 [5.35]	358 [14.09]	390 [15.35]				
		107 [4.21]	139 [5.47]	371 [14.61]	403 [15.87]	250 [9.84]	4 Aluminium full-ridged with bias		
		121 <sup>2)</sup> [4.76]	153 <sup>2)</sup> [6.02]	396 [15.59]	428 [16.85]				
		133 [5.24]	165 [6.50]	421 [16.57]	453 [17.83]	300 [11.81]	5 Aluminium full-ridged without bias		
		144 [5.67]	176 [6.93]	446 [17.56]	478 [18.82]				
		146 <sup>2)</sup> [5.75]	178 <sup>2)</sup> [7.01]	496 [19.53]	528 [20.79]	350 [13.78]	6 Aluminium half-ridged with bias		
		158 [6.22]	190 [7.48]	546 [21.50]	578 [22.76]				
		164 [6.46]	196 [7.72]				7 Aluminium half-ridged without bias		
		171 [6.73]	203 [7.99]						
		182 <sup>2)</sup> [7.17]	214 <sup>2)</sup> [8.43]				9 Special version (on request)		
		196 <sup>2)</sup> [7.72]	228 <sup>2)</sup> [8.98]						
		208 [8.19]	240 [9.45]						
		220 <sup>2)</sup> [8.66]	252 <sup>2)</sup> [9.92]						

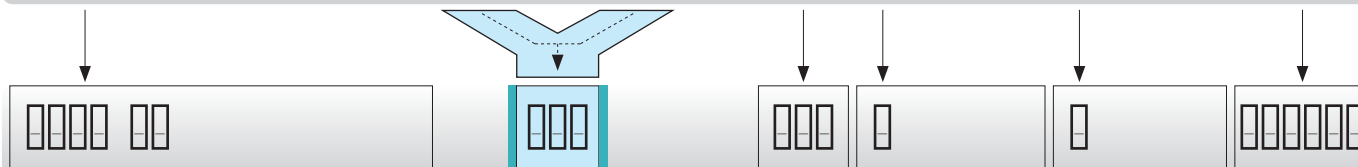

SAMPLE ORDER: 0522 30 220 100 0 0 1365

Frame bridge in outside bend, frame bridge in inside bend, can be opened from inside and outside bend  
 Inside width 220 mm, radius 100 mm  
 Plastic bridge, full-ridged with bias, material black-coloured polyamide  
 Chain length 1365 mm (15 links)

<sup>1)</sup> for Variant 30 only  
<sup>2)</sup> also available with plastic cover  
<sup>3)</sup> Reduced inner height, reduced max. cable diameter, see chain window drawing Page 2

**NOTE ON CONFIGURATION**

**Aluminium frame bridges:**

Aluminium frame bridges can be supplied in 1 mm width sizes for inner widths from 67.0 mm – 600.0 mm .

**Aluminium covers:**

Aluminium covers can be supplied in 1 mm width sizes for inner widths from 43.0 mm – 600.0 mm .

**Crossbar connector and frame bridge strain relief plate:**

Once inner widths exceed 246 mm, we recommend the deployment of crossbar connectors (RSV).  
Crossbar connectors cannot be used in conjunction with covers

made from plastic or aluminium.

If frame bridge strain relief plates (RS-ZL) are to be deployed in the chain brackets, take standard inside widths into account.

For detailed information, please consult the corresponding product documentation.

**SELF-SUPPORTING LENGTH**

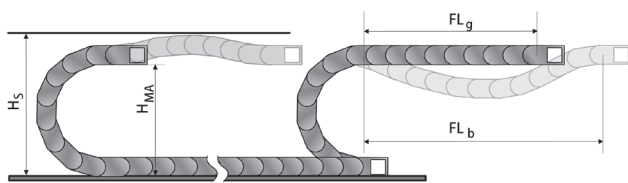

The self-supporting length is the distance between the chain bracket on the moving end and the start of the chain arch. The installation variant  $FL_g$  offers the lowest load and wear for the cable drag chain. The maximum travel parameters (speed and acceleration) can be applied for this variant.

- $H_s$  = Installation height plus safety
- $H_{MA}$  = Height of moving end connection
- $FL_g$  = Self-supporting length, upper run straight
- $FL_b$  = Self-supporting length, upper run bent

**LOAD DIAGRAM FOR SELF-SUPPORTING APPLICATIONS**

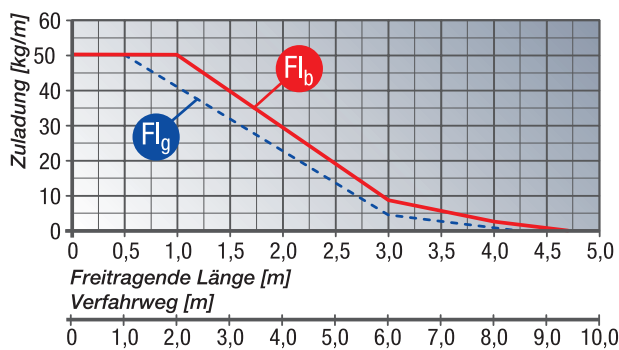

**$FL_g$  Self-supporting length, upper run straight**

In the  $FL_g$  range, the chain upper run still has a bias, is straight or has a maximum sag of 70.0 mm.

**$FL_b$  Self-supporting length, upper run bent**

In the  $FL_b$  range, the chain upper run has a sag of more than 70.0 mm, but this is still less than the maximum sag. Where the sag is greater than that permitted in the  $FL_b$  range, the application is critical and should be avoided. The self-supporting length can be optimized by using a support for the upper run or a more stable energy chain.

Closed cable drag chains (with covers) have a higher unit weight than open chains (with frame bridges). This higher weight must be taken into account when calculating the self-supporting length. To the weight of the cabling (cable load, in kg/m), you must add 1.5 kg/m, to account for the higher weight of closed-cover chains.

**DETERMINING THE CHAIN LENGTH**

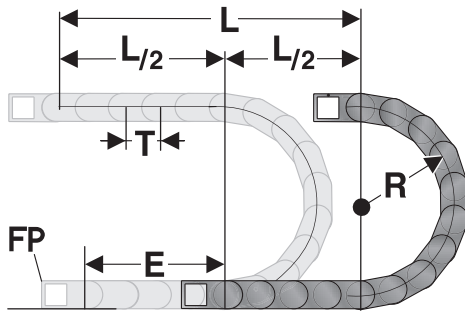

The fixed point of the cable drag chain should be connected in the middle of the travel distance.

This arrangement gives the shortest connection between the fixed point (FP) and the moving consumer and thus the most efficient chain length.

Chain length calculation =  $L/2 + \pi * R + E$   
 $\approx 1 \text{ m chain} = 11 \text{ qty. x } 91.0 \text{ mm links.}$

E = distance between entry point and middle of travel distance

L = travel distance

R = radius

T = Pitch 91.0 mm

**EINBAUMASSE**

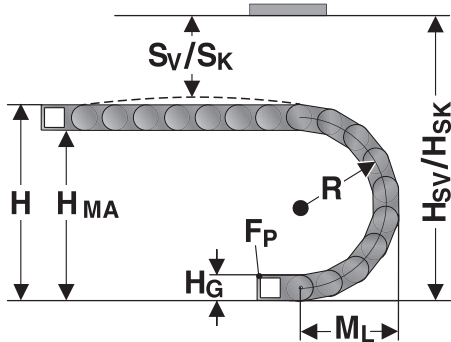

The moving end chain connection is to be screw fixed at height  $H_{MA}$  for the respective radius.

Concerning the installed dimensions, you must take into account whether the chain links are equipped with or without bias.

For chain links without bias, the „Installed height without bias  $H_{SK}$ “ value has to be taken into account.

If the chain links are equipped with a bias, the value „Installed height with bias  $H_{SV}$ “ has to be taken into account.

Radius R	100	150	175	200	250	300	350
Outside height of chain link ( $H_c$ )	75	75	75	75	75	75	75
Height of bend (H)	305	405	455	505	605	705	805
Height of moving end bracket ( $H_{MA}$ )	230	330	380	430	530	630	730
Safety margin with bias ( $S_v$ )	46	46	46	46	46	46	46
Installation height with bias ( $H_{sv}$ )	351	451	501	551	651	751	851
Safety margin without bias ( $S_k$ )	16	16	16	16	16	16	16
Installation height without bias ( $H_{sk}$ )	321	421	471	521	621	721	821
Arc projection ( $M_L$ )	244	294	319	344	394	444	494

## POWERLINE PLASTIC FRAME BRIDGE



Frame bridge

The frame bridges connect the two side runs of the energy chain. The frame bridge length is synonymous with the inside width of the energy chain.

Type	Order No.	Designation
RS 045-5	052004500000	Frame bridge
RS 057-5	052005700000	Frame bridge
RS 062-5	052006200000	Frame bridge
RS 071-5	052007100000	Frame bridge
RS 084-5	052008400000	Frame bridge
RS 093-5	052009300000	Frame bridge
RS 096-5	052009600000	Frame bridge
RS 104-5	052010400000	Frame bridge
RS 107-5	052010700000	Frame bridge
RS 121-5	052012100000	Frame bridge
RS 133-5	052013300000	Frame bridge
RS 144-5	052014400000	Frame bridge
RS 146-5	052014600000	Frame bridge
RS 158-5	052015800000	Frame bridge
RS 164-5	052016400000	Frame bridge
RS 171-5	052017100000	Frame bridge
RS 182-5	052018200000	Frame bridge
RS 196-5	052019600000	Frame bridge
RS 208-5	052020800000	Frame bridge
RS 220-5	052022000000	Frame bridge
RS 233-5	052023300000	Frame bridge
RS 246-5	052024600000	Frame bridge
RS 252-5	052025200010	Frame bridge
RS 258-5	052025800000	Frame bridge
RS 296-5	052029600000	Frame bridge
RS 346-5	052034600000	Frame bridge
RS 350-5	052035000000	Frame bridge
RS 358-5	052035800000	Frame bridge
RS 371-5	052037100000	Frame bridge
RS 396-5	052039600000	Frame bridge
RS 421-5	052042100000	Frame bridge
RS 446-5	052044600000	Frame bridge
RS 496-5	052049600000	Frame bridge
RS 546-5	052054600000	Frame bridge

## MP 52.3 / MP 52.5 PLASTIC COVER



Cover

The covers connect the two side runs of the energy chain. The cover length is synonymous with the inside width of the energy chain.

Type	Order No.	Designation	Installation site
A-523096, outside	052309610000	Cover	Outside bend
I-523096, inside	052309620000	Cover	Inside bend
A-523121, outside	052312110000	Cover	Outside bend
I-523121, inside	052312120000	Cover	Inside bend
A-523146, outside	052314610000	Cover	Outside bend
I-523146, inside	052314620000	Cover	Inside bend
A-523182, outside	052318210000	Cover	Outside bend
I-523182, inside	052318220000	Cover	Inside bend
A-523196, outside	052319610000	Cover	Outside bend
I-523196, inside	052319620000	Cover	Inside bend
A-523220, outside	052322010000	Cover	Outside bend
I-523220, inside	052322020000	Cover	Inside bend
A-523246, outside	052324610000	Cover	Outside bend
I-523246, inside	052324620000	Cover	Inside bend
A-523296, outside	052329610000	Cover	Outside bend
I-523296, inside	052329620000	Cover	Inside bend
A-523346, outside	052334610000	Cover	Outside bend
I-523346, inside	052334620000	Cover	Inside bend

**KA 52.1 FLEXIBLE CHAIN BRACKET**

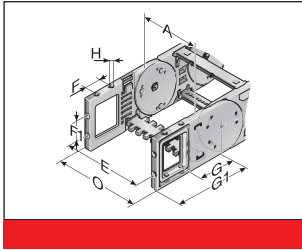

This chain bracket offers universal connection options (top, bottom and front) and is attached to the ends of the chain like a side link. This allows the chain to move right up to the bracket. Each chain requires one male and one female bracket. M8 screws are used to secure the brackets in place. Extrusion-coated metal bushes with either a through-hole (-FB) or a threaded hole (-FG) ensure the permanent, high-strength transmission of even extreme forces onto the cable drag chain.

Type	Order No.	Material	Version	Inside width								Outside width KA	
				A mm	E mm	F mm	F1 mm	G mm	G1 mm	H mm	H0 mm	O mm	
KA 52.1-FB Female end	0521000056	Plastic	with bush	45.0 – 546.0	A+16.0	35.0	30.0	89.0	146.0	8.5		A+36.0	
KA 52.1-FB Male end	0521000057	Plastic	with bush	45.0 – 546.0	A+16.0	35.0	30.0	89.0	146.0	8.5		A+36.0	
KA 52.1-FG Female end	0521000058	Plastic	with thread	45.0 – 546.0	A+16.0	35.0	30.0	89.0	146.0	M8		A+36.0	
KA 52.1-FG Male end	0521000059	Plastic	with thread	45.0 – 546.0	A+16.0	35.0	30.0	89.0	146.0	M8		A+36.0	

**CHAIN BRACKET ANGLE KA 52.1**

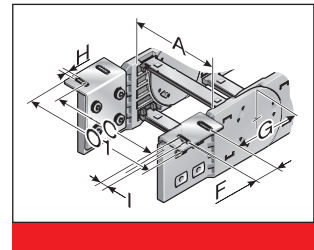
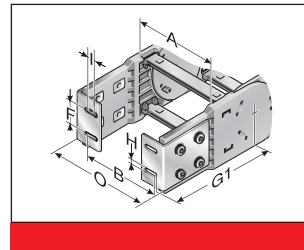
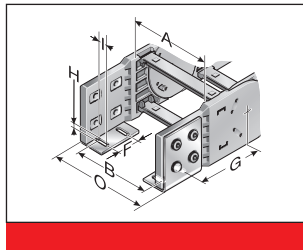
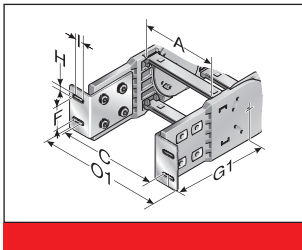

There are several options regarding the chain bracket. The fixed-point bracket (inside/bottom) and the moving end bracket (inside/top) are supplied as standard. However, any other combination can be supplied upon request. The chain bracket

is fastened at the end like a side link. This enables the chain to move right up to the bracket. Each chain requires one male and one female bracket. The brackets should be fastened with M6 screws.

Type	Order No.	Material	Inside width								Outside width KA		
			A mm	B mm	C mm	F mm	G mm	G1 mm	H0 mm	I mm	O mm	O1 mm	
KA 52.1 Female end	0521000050	Sheet steel	45.0 – 546.0	A-2.5	A+34.5	32.0	95.5	144.0	6.5	14.0		A+32.0	A+71.0
KA 52.1 Male end	0521000051	Sheet steel	45.0 – 546.0	A-2.5	A+34.5	32.0	95.5	144.0	6.5	14.0		A+32.0	A+71.0

MP 52.2 OPEN / MP 52.3 CLOSED

**GS 52.2 SLIDING BLOCK**

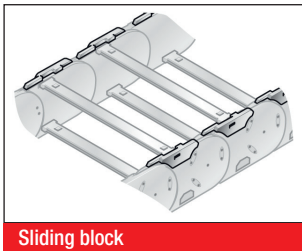

Sliding block

In the case of energy chains, sliding blocks are used in a horizontally sliding installation mode (the tight side of the chain slides on the slack side). The sliding blocks are set onto the side links on the interior bend instead of the usual frame bridge interlocks; (no tools needed). This forces the chain to slide on the sliding blocks instead on the side links of the chain.

Depending on the application, the service life of the energy chain may be extended five-fold, by using sliding blocks.

Type	Order No.	Installation site	Min. radius mm	Sliding block height mm
GS 52.2.1 right	052290400302	For right side link	150.0	4.0
GS 52.2.2 left	052290400300	For left side link	150.0	4.0

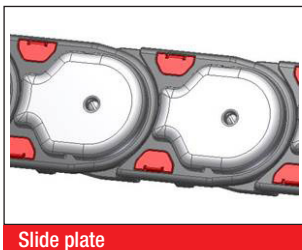

Slide plate

Order No.	Installation site	For radius mm	Slide plate height mm
052200010066	Right chain link including slide plate	100.0	7.0
052200010064	Left chain link including slide plate	100.0	7.0
052200015066	Right chain link including slide plate	150.0	7.0
052200015064	Left chain link including slide plate	150.0	7.0
052200017566	Right chain link including slide plate	175.0	7.0
052200017564	Left chain link including slide plate	175.0	7.0
052200020066	Right chain link including slide plate	200.0	7.0
052200020064	Left chain link including slide plate	200.0	7.0

Order No.	Installation site	For radius mm	Slide plate height mm
052200025066	Right chain link including slide plate	250.0	7.0
052200025064	Left chain link including slide plate	250.0	7.0
052200030066	Right chain link including slide plate	300.0	7.0
052200030064	Left chain link including slide plate	300.0	7.0
052200035066	Right chain link including slide plate	350.0	7.0
052200035064	Left chain link including slide plate	350.0	7.0

**SEPARATOR TR 52**

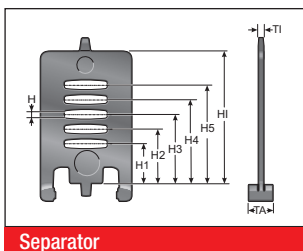

Separator

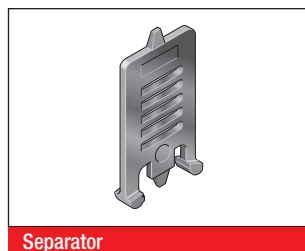

Separator

We recommend that separators be used if multiple round cables or conduits with differing diameters are to be installed. The closed separator is used when no shelves are used. This is the recommended design for travel paths of 30 metres or greater.

Type	Order No.	Designation	Version	Tl mm	TA mm	H mm	H1 mm	H2 mm	H3 mm	H4 mm	H5 mm	Hl mm
TR 52	052000009200	TR 52 Separator	lockable	3.5	10.0	4.2	16.3	22.3	28.2	33.8	39.8	52.0

**SEPARATOR TR 52.1**

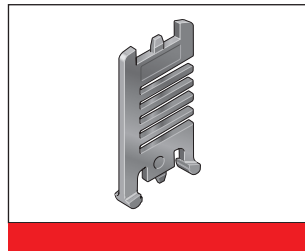
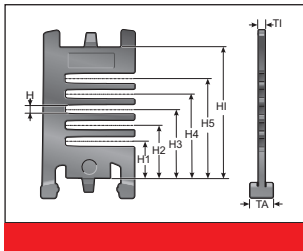

We recommend that separators be used if multiple round cables or conduits with differing diameters are to be installed.

Type	Order No.	Designation	Version	TI mm	TA mm	H mm	H1 mm	H2 mm	H3 mm	H4 mm	H5 mm	HI mm
TR 52.1	052100009200	TR 52.1 Separator	lockable	3.5	8.0	4.0	15.6	22.0	28.2	34.6	41.0	52.0

**TR 52-V SEPARATOR**

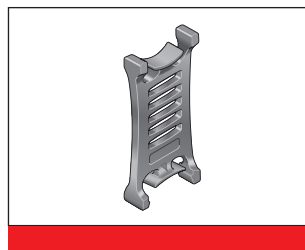
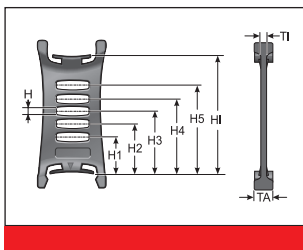

Das Verlegen mehrerer Rundleitungen oder Schläuche mit unterschiedlichen Durchmessern ist nur bei Verwendung von Trennstegen zu empfehlen.

Type	Order No.	Designation	Version	TI mm	TA mm	H mm	H1 mm	H2 mm	H3 mm	H4 mm	H5 mm	HI mm
TR 52-V	052000009300	TR 52-V Separator	moveable	3.5	13.0	4.0	16.3	22.3	28.2	33.8	39.8	52.0

**RTT 52 SHELF SUPPORT, DIVISIBLE**

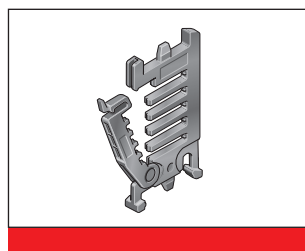
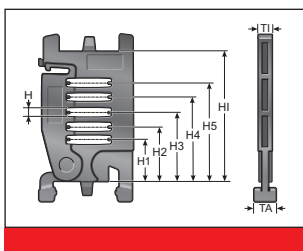

Zwei teilbare Regalträger (RTT) ergeben in Verbindung mit mindestens einem Regalboden (RB) ein einfach zu befüllendes Regalsystem. Die zusätzlichen Ebenen/Etagen verhindern das Verdrehen der Leitungen und minimieren die Reibung der Leitungen untereinander.

Type	Order No.	Designation	Version	TI mm	TA mm	H mm	H1 mm	H2 mm	H3 mm	H4 mm	H5 mm	H6 mm	H7 mm	HI mm
RTT 52	100090522000	Shelf support, divisible	lockable	7.0	8.0	4.0	15.6	22.0	28.2	34.6	41.0			52.0

## RB-5 SHELF

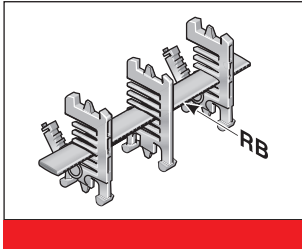

In connection with at least two separable shelf supports (RTT), the shelf becomes a shelving system. The additional levels prevent cables from criss-crossing and minimise the friction between them.

Type	Order No.	Designation	Width mm	für Innenbreite mm
RB 028-5	10000002800	Shelf	28.0	45.0
RB 034-5 shelf 034-5mm	1000003405	Shelf	33.6	45.0
RB 039-5 shelf 039-5mm	1000003905	Shelf	39.2	45.0
RB 045-5 shelf 045-5mm	1000004505	Shelf	44.8	57.0
RB 050-5 shelf 050-5mm	1000005005	Shelf	50.4	57.0
RB 056-5	10000005601	Shelf	56.0	62.0
RB 062-5 shelf 062-5mm	1000006205	Shelf	61.6	62.0
RB 067-5 shelf 067-5mm	1000006705	Shelf	67.2	84.0
RB 073-5 shelf 073-5mm	1000007305	Shelf	72.8	84.0
RB 078-5 shelf 078-5mm	1000007805	Shelf	78.4	84.0
RB 084-5	10000008400	Shelf	84.0	84.0
RB 090-5 shelf 090-5mm	1000009005	Shelf	89.6	96.0
RB 095-5 shelf 095-5mm	1000009505	Shelf	95.2	96.0
RB 101-5 shelf 101-5mm	1000010105	Shelf	100.8	107.0
RB 106-5 shelf 106-5mm	1000010605	Shelf	106.4	107.0
RB 112-5	100000011200	Shelf	112.0	121.0
RB 118-5 shelf 118-5mm	1000011805	Shelf	117.6	121.0
RB 123-5 shelf 123-5mm	1000012305	Shelf	123.2	133.0
RB 129-5 shelf 129-5mm	1000012905	Shelf	128.8	133.0
RB 134-5 shelf 134-5mm	1000013405	Shelf	134.4	144.0
RB 140-5	100000014000	Shelf	140.0	144.0
RB 146-5 shelf 146-5mm	1000014605	Shelf	145.6	158.0
RB 151-5 shelf 151-5mm	1000015105	Shelf	151.2	158.0
RB 157-5 shelf 157-5mm	1000015705	Shelf	156.8	164.0
RB 162-5 shelf 162-5mm	1000016205	Shelf	162.4	164.0
RB 168-5	100000016800	Shelf	168.0	182.0
RB 174-5 shelf 174-5mm	1000017405	Shelf	173.6	182.0
RB 179-5 shelf 179-5mm	1000017905	Shelf	179.2	196.0
RB 185-5 shelf 185-5mm	1000018505	Shelf	184.8	196.0
RB 190-5 shelf 190-5mm	1000019005	Shelf	190.4	196.0
RB 196-5	100000019600	Shelf	196.0	196.0
RB 291-5	100000029100	Shelf	291.2	346.0

## CROSSBAR CONNECTOR RSV 52

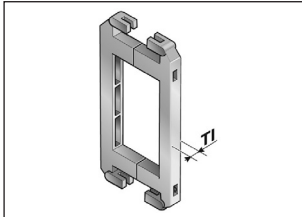

Crossbar connector

For frame bridges wider than 246 mm, we recommend the use of crossbar connectors. These prevent deformation to the frame bridge under large amounts of additional weight of the chain assembly.

Type	Order No.	Designation	T1 mm
RSV 52	052000009600	Crossbar connector	7.5
RSV 52 Alu	052000009800	Crossbar connector for aluminium frame bridges	7.5

**RE 52 H-SHAPED SHELF UNIT**

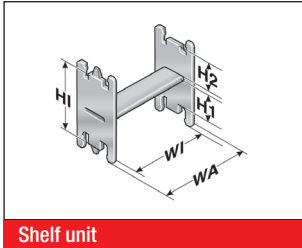

One-piece shelving system, the shelf cannot be varied in height.

Shelf unit

Type	Order No.	Designation	WA mm	WI mm	H1 mm	H2 mm	HI mm
RE 36/17	100000361714	H-shaped shelf unit	42.5	36.5	31.0	17.4	52.0
RE 59/24	100000592414	H-shaped shelf unit	65.0	59.0	24.2	24.2	52.0
RE 81/12	100000811214	H-shaped shelf unit	87.5	81.5	36.0	12.4	52.0

**BS -5 BRACKET BAR**

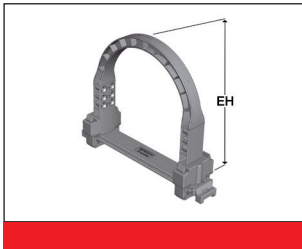

Large-diameter conduits are routed securely by using a bracket bar (BS). This bar is installed on the frame bridges or the covers of the cable drag chain.

The bracket bar can be installed on both the inside and outside bend.

The bracket bar support (BSH) is used to attach the bars to PowerLine series frame bridges. Two bracket bar supports are required for each bar.

Type	Order No.	Designation	Conduit diameter max. mm	Installation height mm	Inner chain width min. mm
BS 120-5	052412000000	Extender frame bridge	115.0	140.0	164.0
BS 153-5	052415300000	Extender frame bridge	148.0	170.0	208.0
BS 187-5	052418700000	Extender frame bridge	182.0	205.0	233.0
BSH-5	052400000000	Extender frame bridge holder			

**COVER CHAIN BRACKET D5**

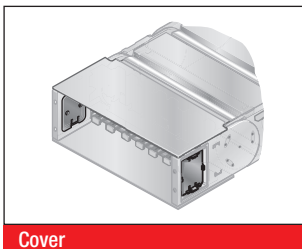

Cover

Self-locking covers close the side mounting window on the flexible chain bracket (KA-FB/FG).

Type	Order No.
Cover D5 KA 52.1-FB/FG	0523888002

**MP 52.3 CHAIN BRACKET CANOPY**

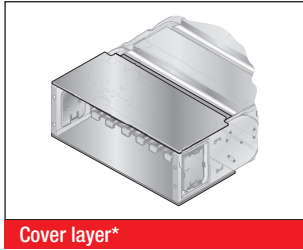

Constructed from aluminium, the canopies for the flexible chain bracket (KA-FB/FG) ensure a continuously closed system for chains with covers.

Canopy for chain bracket, fixed point outside bend: Type and part number configurator

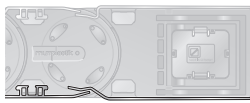

Type:	KA 52.1 FB/FG AB	Inside width	2-2
Order No.:	0521	Inside width	060

Cover for chain bracket fixed point inside bend: Type and part number configurator



Type:	KA 52.1 FB/FG IB	Inside width	2-2
Order No.:	0521	Inside width	058

Cover for chain bracket moving end outside bend: Type and part number configurator

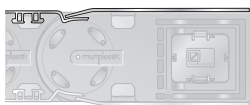

Type:	KA 52.1 FB/FG AB	Inside width	1-2
Order No.:	0521	Inside width	059

Cover for chain bracket moving end inside bend: Type and part number configurator

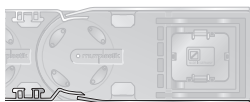

Type:	KA 52.1 FB/FG IB	Inside width	1-2
Order No.:	0521	Inside width	057

**Sample order:**

0521096058 KA 52.1 FB/FG IB 096 2-2

Chain bracket cover at fixing point in inner bend, for inner width of 96 mm.

**RS-ZL-5 FRAME RAIL TENSION RELIEF**

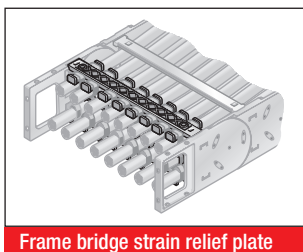

Fixed integrated frame bridge strain relief plates in the chain brackets. Tailored to all frame bridge widths up to 246 mm. May be assembled on the inside and outside bends at both chain endings.

Type	Order No.	Designation	für Innenbreite mm
RS-ZL 045-5	052004500010	Frame bridge strain relief plate	45.0
RS-ZL 057-5	052005700010	Frame bridge strain relief plate	57.0
RS-ZL 062-5	052006200010	Frame bridge strain relief plate	62.0
RS-ZL 071-5	052007100010	Frame bridge strain relief plate	71.0
RS-ZL 084-5	052008400010	Frame bridge strain relief plate	84.0

**RS-ZL-5 FRAME RAIL TENSION RELIEF**

Type	Order No.	Designation	für Innenbreite mm
RS-ZL 093-5	052009300010	Frame bridge strain relief plate	93.0
RS-ZL 096-5	052009600010	Frame bridge strain relief plate	96.0
RS-ZL 104-5	052010400010	Frame bridge strain relief plate	104.0
RS-ZL 107-5	052010700010	Frame bridge strain relief plate	107.0
RS-ZL 121-5	052012100010	Frame bridge strain relief plate	121.0
RS-ZL 133-5	052013300010	Frame bridge strain relief plate	133.0
RS-ZL 144-5	052014400010	Frame bridge strain relief plate	144.0
RS-ZL 146-5	052014600010	Frame bridge strain relief plate	146.0
RS-ZL 158-5	052015800010	Frame bridge strain relief plate	158.0
RS-ZL 164-5	052016400010	Frame bridge strain relief plate	164.0
RS-ZL 171-5	052017100010	Frame bridge strain relief plate	171.0
RS-ZL 182-5	052018200010	Frame bridge strain relief plate	182.0
RS-ZL 196-5	052019600010	Frame bridge strain relief plate	196.0
RS-ZL 208-5	052020800010	Frame bridge strain relief plate	208.0
RS-ZL 220-5	052022000010	Frame bridge strain relief plate	220.0
RS-ZL 233-5	052023300010	Frame bridge strain relief plate	233.0
RS-ZL 246-5	052024600010	Frame bridge strain relief plate	246.0

**STRAIN RELIEF WITH STEEL FIX**

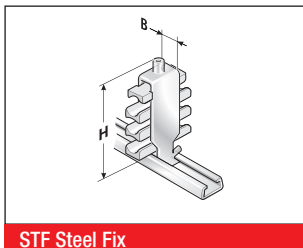

STF Steel Fix

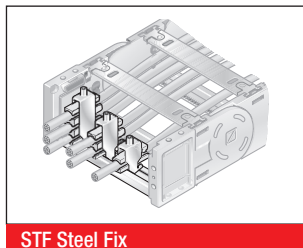

STF Steel Fix

C-rails (cathodic dipped) for permanent integration, for accommodating the Steel Fix bow clamps in the chain brackets. The bow clamps can take up to 3 cables and are suitable for C-rails with a groove width of 11 mm. Due to the design of the trough elements, a cable preserving cable guidance is ensured. May be assembled on the inside and outside bends at both chain endings. The overall height stated is a guide only. The actual height is, amongst other things, dependent on the diameter and the quality of the cable. A safety distance of 10 mm at the fixed point above the strain relief must be kept during gliding applications.

Type	Order No.	Designation	Seats qty.	Cable Ø mm	Width (B) mm	Overall height (H) mm
<b>Single clamp (for two cables)</b>						
STF 12-1 Steel Fix	81661801	Hooped clamp	1	6.0 – 12.0	16.0	55.0
STF 14-1 Steel Fix	81661802	Hooped clamp	1	12.0 – 14.0	18.0	52.0
STF 16-1 Steel Fix	81661803	Hooped clamp	1	14.0 – 16.0	20.0	54.0
STF 18-1 Steel Fix	81661804	Hooped clamp	1	16.0 – 18.0	22.0	56.0
STF 20-1 Steel Fix	81661805	Hooped clamp	1	18.0 – 20.0	24.0	59.0
STF 22-1 Steel Fix	81661806	Hooped clamp	1	20.0 – 22.0	26.0	61.0
STF 26-1 Steel Fix	81661807	Hooped clamp	1	22.0 – 26.0	30.0	70.0
STF 30-1 Steel Fix	81661808	Hooped clamp	1	26.0 – 30.0	34.0	74.0
STF 34-1 Steel Fix	81661809	Hooped clamp	1	30.0 – 34.0	38.0	78.0
STF 38-1 Steel Fix	81661810	Hooped clamp	1	34.0 – 38.0	42.0	82.0
STF 42-1 Steel Fix	81661811	Hooped clamp	1	38.0 – 42.0	46.0	91.0

**STRAIN RELIEF WITH STEEL FIX**

Type	Order No.	Designation	Seats qty.	Cable Ø mm	Width (B) mm	Overall height (H) mm
<b>Double clamp (for two cables)</b>						
STF 12-2 Steel Fix	81661821	Hooped clamp	2	6.0 – 12.0	16.0	73.0
STF 14-2 Steel Fix	81661822	Hooped clamp	2	12.0 – 14.0	18.0	74.0
STF 16-2 Steel Fix	81661823	Hooped clamp	2	14.0 – 16.0	20.0	82.0
STF 18-2 Steel Fix	81661824	Hooped clamp	2	16.0 – 18.0	22.0	86.0
STF 20-2 Steel Fix	81661825	Hooped clamp	2	18.0 – 20.0	24.0	91.0
STF 22-2 Steel Fix	81661826	Hooped clamp	2	20.0 – 22.0	26.0	95.0
STF 26-2 Steel Fix	81661827	Hooped clamp	2	22.0 – 26.0	30.0	108.0
STF 30-2 Steel Fix	81661828	Hooped clamp	2	26.0 – 30.0	34.0	121.0
STF 34-2 Steel Fix	81661829	Hooped clamp	2	30.0 – 34.0	38.0	129.0
<b>Triple clamp (for three cables)</b>						
STF 12-3 Steel Fix	81661841	Hooped clamp	3	6.0 – 12.0	16.0	98.0
STF 14-3 Steel Fix	81661842	Hooped clamp	3	12.0 – 14.0	18.0	98.0
STF 16-3 Steel Fix	81661843	Hooped clamp	3	14.0 – 16.0	20.0	105.0
STF 18-3 Steel Fix	81661844	Hooped clamp	3	16.0 – 18.0	22.0	111.0
STF 20-3 Steel Fix	81661845	Hooped clamp	3	18.0 – 20.0	24.0	118.0
STF 22-3 Steel Fix	81661846	Hooped clamp	3	20.0 – 22.0	26.0	130.0

**MP 52/62/72 LOCK BUTTON**

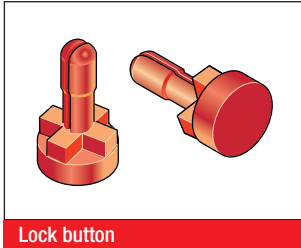
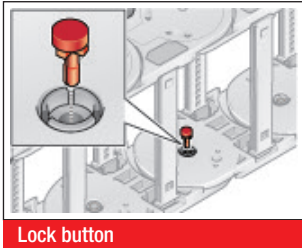
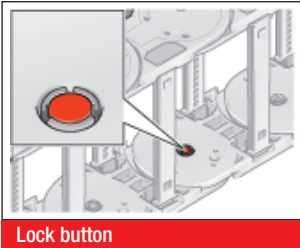

To increase the side stability, we recommend the use of lock buttons during strong lateral acceleration or when installed

„laying on the side (turned 90°) without support“.

Type	Order No.
MP52/62/72 lock button	0520000080

**LOWERED FIXING POINT MP 52**

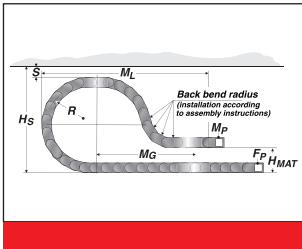
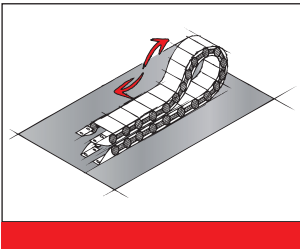

It is sometimes necessary to lower the height of the moving attachment point.

In such cases, modifications to the chain layout should be noted (e.g. extension of chain).

Please contact our application engineers.

Radius R mm	Height of moving end bracket (H <sub>MA</sub> ) mm	Safety margin (S) mm	Installation height incl. safety (H <sub>S</sub> ) mm	Projection (M <sub>L</sub> ) mm	Additional links qty.	of which additional back chain links qty.
175.0	180.0	50.0	515.0	620.0	6	3
200.0	210.0	50.0	565.0	830.0	10	3
250.0	250.0	50.0	665.0	990.0	13	3
300.0	300.0	50.0	765.0	900.0	14	3
350.0	330.0	50.0	865.0	1180.0	16	3

MP 52.2 OPEN / MP 52.3 CLOSED

**REAR-FACING MP 52.2**

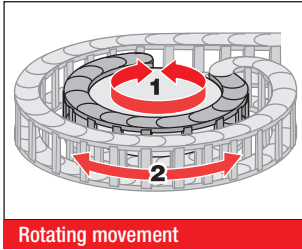

Side links with radius forward (R) and radius backward (Rü) allow for movement in two directions. This is intended for rotating movements and lowered chain brackets. Note: This type of chain has different chain links for the left or right side!

Type	Order No.	Radius mm	Rear-facing radius mm
SR 52.2 (RÜ300/R135) left	052200010060	135.0	200.0
SR 52.2 (RÜ300/R135) right	052200010062	135.0	200.0
SR 52.2 (RÜ200/R170) left	052200015060	170.0	200.0
SR 52.2 (RÜ200/R170) right	052200015062	170.0	200.0
SR 52.2 (RÜ200/R200) left	052200020060	200.0	200.0
SR 52.2 (RÜ200/R200) right	052200020062	200.0	200.0
SR 52.2 (RÜ200/R250) left	052200025060	250.0	200.0
SR 52.2 (RÜ200/R250) right	052200025062	250.0	200.0
SR 52.2 (RÜ200/R300) right	052200030062	300.0	200.0
SR 52.2 (RÜ200/R350) left	052200035060	350.0	200.0
SR 52.2 (RÜ200/R350) right	052200035062	350.0	200.0

### GUIDE CHANNEL VAW (ALUMINIUM / STAINLESS STEEL)

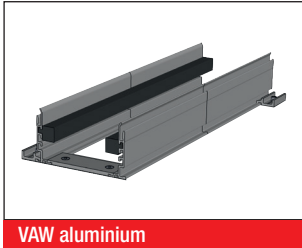

VAW aluminium



VAW stainless steel

For this cable drag chain, a range of variable guide channel systems are available, constructed from aluminium or stainless steel sections.

The variable guide channel ensures that the cable drag chain is supported and guided securely.

For help on choosing, please consult the chapter „Variable Guide Channel System“.

### ASSEMBLY INSTRUCTION FLEXIBLE CHAIN BRACKET FB/FG

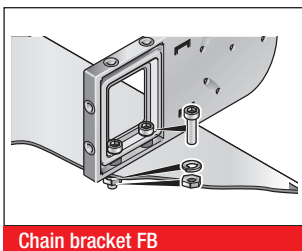

Chain bracket FB

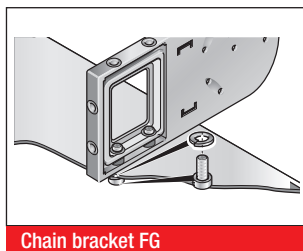

Chain bracket FG

Brass bushes guarantee long-lasting fastening without cold flow in the plastic.

**Version KA-FB:**

Integrated through-hole fastened down using screw and nut.

**Version KA-FG:**

Built-in threads allow for quick and easy on-site mounting, since a screw, including a retaining washer where necessary, is sufficient.

**ASSEMBLY**

**DISASSEMBLY**

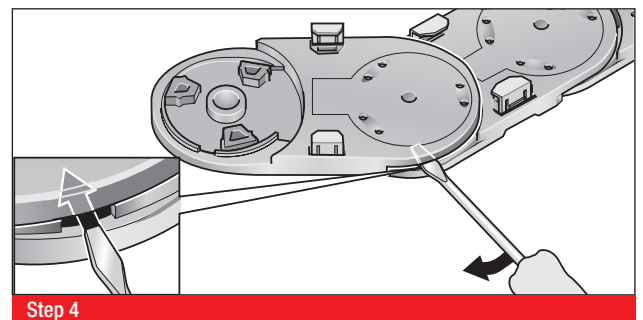
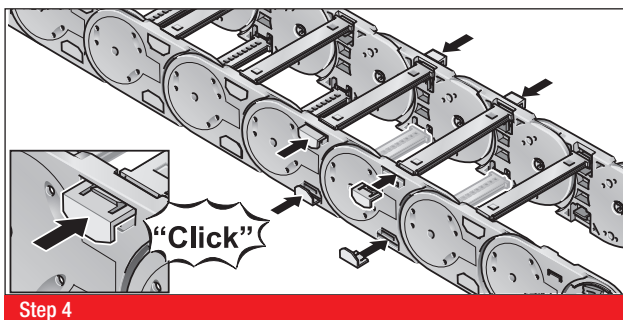
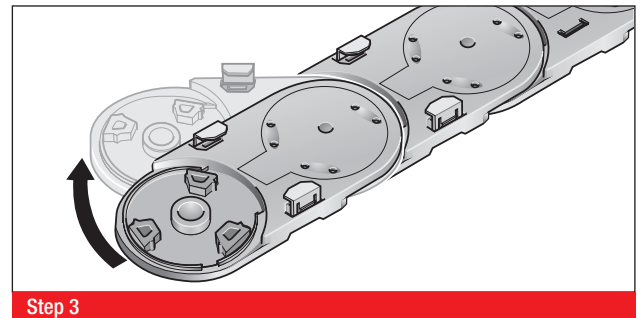
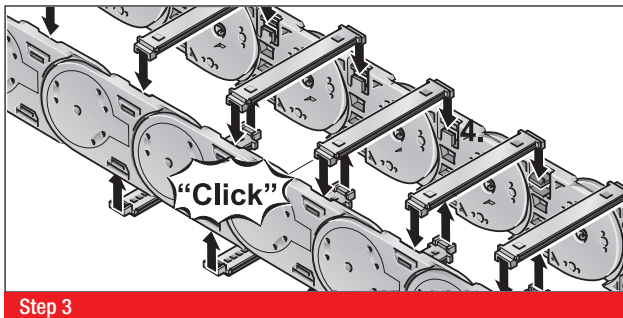
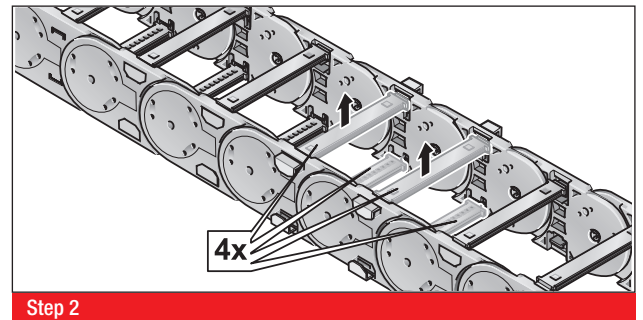
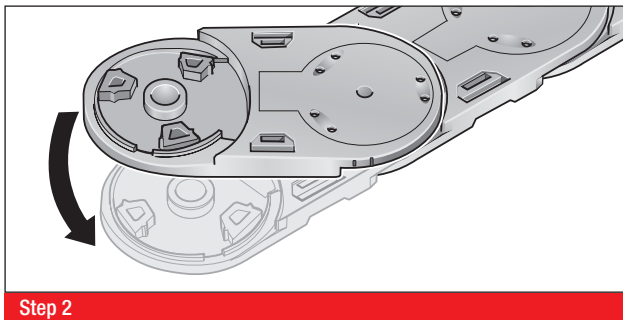
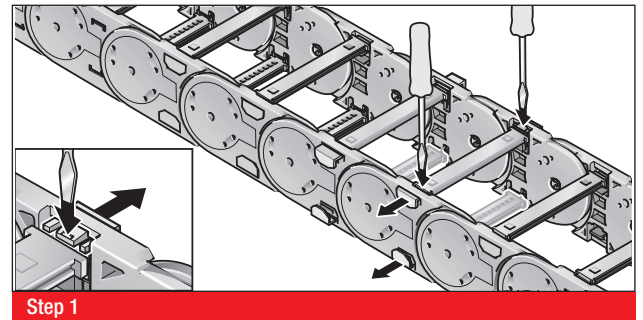
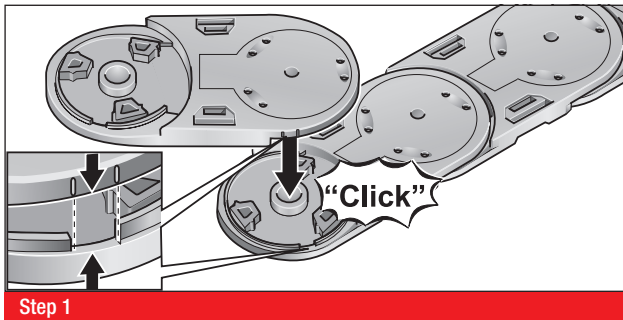

All details given in our sales material prospectuses and catalogues as well as the information available online are based on our current knowledge of the products described.

The electronic data and files made available by Murrplastik, particularly CAD files are based on our current knowledge of the product described.

A legally binding assurance of certain properties or the suitability for a certain purpose can not be determined from this information.

All information with respect to the chemical and physical properties of Murrplastik products as well as application advice given verbally, in writing or by tests, is given to the best of our knowledge.

This does not free the purchaser of carrying out their own inspections and tests in order to determine the suitability of a product for a specific purpose.

Murrplastik accepts no responsibility for the available information being up-to-date, correct or complete. Neither do we accept responsibility for the quality of this information.

Murrplastik reserves the right to make technical changes and improvements through constant further development of products and services.

Our General Terms and Conditions apply.